

ROOF DRIP SIDE FINISH MOULDING CENTER LH REPLACEMENT

760JJ-01

HINT:

- Installation is in the reverse order of the removal. But the installation is indicated only when it has a point.
- In the RH side, work in the same procedure as in the LH side.

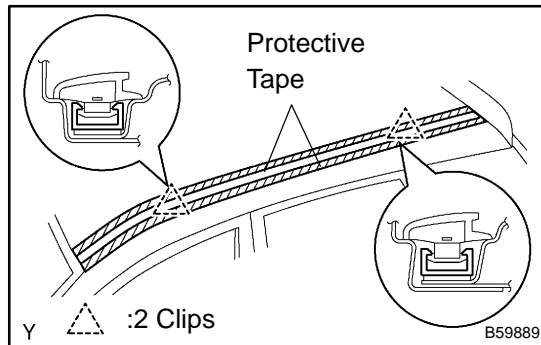

1. REMOVE ROOF DRIP SIDE FINISH MOULDING CENTER LH

- Put protective tape around the roof drip finish moulding.
- Using a screwdriver, disengage the clips of the roof drip finish moulding front end, and remove the moulding.

HINT:

Tape the screwdriver tip before use.

NOTICE:

- Do not remove the clips.
- If the clips are damaged or removed accidentally, exchange them for new ones.

2. INSTALL ROOF DRIP SIDE FINISH MOULDING CLIP NO.1

NOTICE:

Only when exchanging the clips.

- Remove the adhesive tape that remains on the moulding surface of the body, and then clean the surface with white gasoline.
- Heat up the clip and clip installation surfaces of the body with a heat light.

Body: 40 – 60°C (104 – 140°F)

Clip: 20 – 30°C (68 – 86°F)

NOTICE:

Do not heat the body and clip excessively.

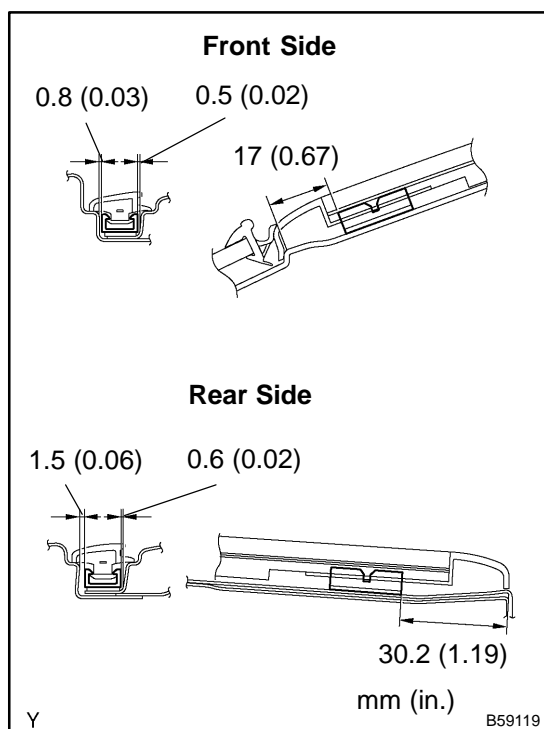

(c) Set the supplied clips into the positions as shown in the illustration, and then press-fit those clips by hand to install them.

(d) Install the moulding when 30 minutes or more have passed after press-fitting the clips.

HINT:

- Initial hardening time: 30 minutes
- Perfect hardening time: 24 hours

3. INSTALL ROOF DRIP SIDE FINISH MOULDING CENTER RH

- (a) Install the roof drip side finish moulding.
- (b) Tap on the moulding by hand.