

DISPOSAL

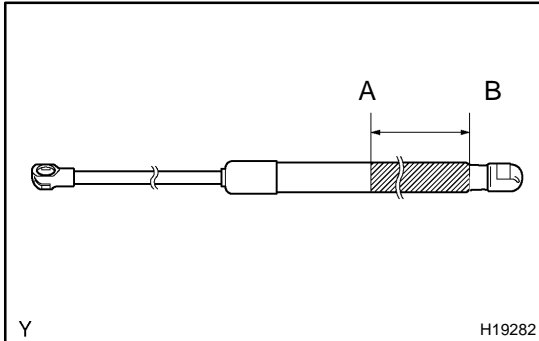

1. DISPOSE BACK DOOR STAY ASSY LH

- (a) Fix the back door stay, with the piston-rod pulled out, on a vise.
- (b) With protection glasses on, drill a 2.0 – 3.0 mm (0.079 – 0.118 in.) hole in the lower half of the bottom (A – B) of the back door stay, as shown in the illustration, to completely release the high-pressure gas before disposing of it.

NOTICE:

When handling the back door stay:

- Do not disassemble the back door stay because the cylinder is filled with pressurized gas.
- When drilling, chips may fly off, so work carefully.
- The gas is colorless, odorless and non-toxic.
- When working, handle the back door stay carefully. Never scratch the exposed part of the piston rod, and never allow paint or oil to get on it.
- Do not turn the piston rod and cylinder with the back door stay fully extended.