

OVERHAUL

HINT:

- Installation is in the reverse order of the removal. But the installation is indicated only when it has a point.
- In the RH side, work in the same procedure as in the LH side.

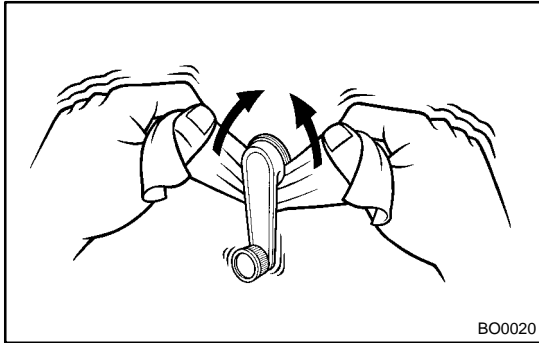

1. REMOVE FRONT DOOR WINDOW REGULATOR HANDLE ASSY (W/O POWER WINDOW)

- Using a shop rag, remove the snap ring.
- Remove the front door window regulator handle and plate.

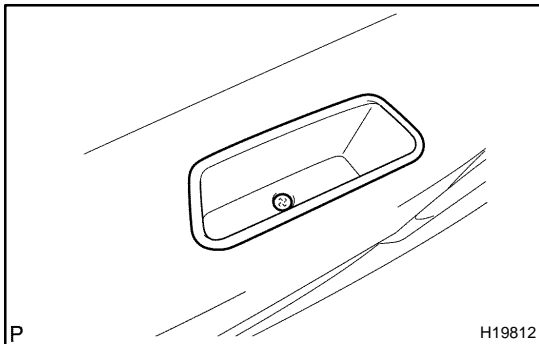

2. REMOVE FRONT DOOR PULL HANDLE LH

- Remove the screw.
- Using a screwdriver, remove the door pull handle.

HINT:

Tape the screwdriver tip before use.

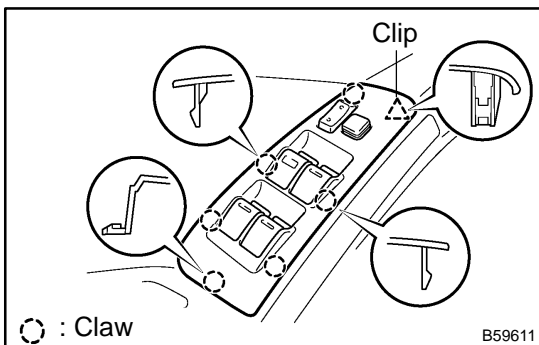

3. REMOVE POWER WINDOW REGULATOR MASTER SWITCH ASSY (W/ POWER WINDOW)

- Using a screwdriver, remove the power window regulator master switch assembly from the trim board.

HINT:

Tape the screwdriver tip before use.

- Disconnect the master switch connector.
- Remove the 3 screws and base panel from the master switch.

4. REMOVE FRONT ARMREST BASE PANEL UPPER LH (W/O POWER WINDOW)

- w/o Power door lock:
Remove the front armrest base panel upper.
 - Using a screwdriver, remove the front armrest base panel upper from the trim board.

HINT:

Tape the screwdriver tip before use.

- w/ Power door lock:
Remove the front armrest base panel upper.
 - Using a screwdriver, remove the front armrest base panel upper from the trim board.

HINT:

Tape the screwdriver tip before use.

- (2) Disconnect the door lock switch connector.
- (3) Remove the door lock switch from the base panel.

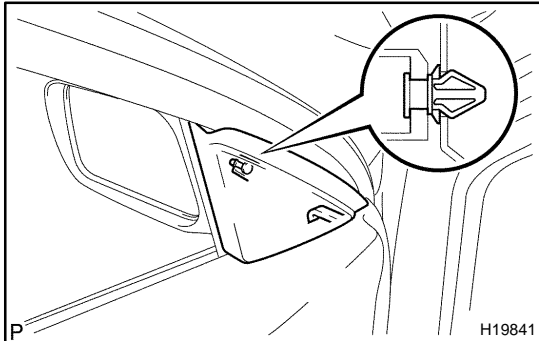

5. REMOVE FRONT DOOR LOWER FRAME BRACKET GARNISH LH

- (a) Remove the lower frame bracket garnish.

6. REMOVE FRONT DOOR TRIM BOARD SUB-ASSY LH

- (a) Remove the screw.

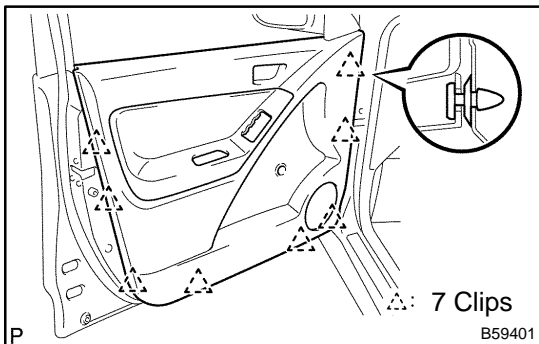

- (b) Using a screwdriver, disengage the clips and then pull the trim board upward to remove it.

HINT:

Tape the screwdriver tip before use.

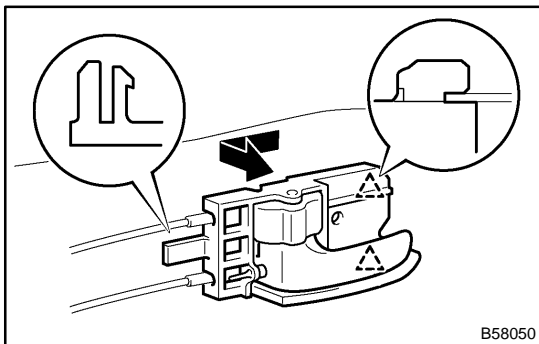

7. REMOVE FRONT DOOR INSIDE HANDLE SUB-ASSY LH

- (a) Remove the inside handle, and then disconnect the 2 cables from the inside handle.

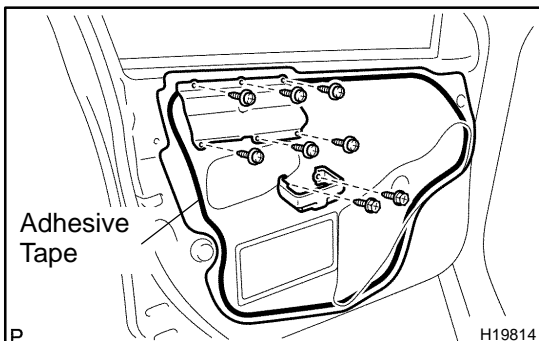

8. REMOVE FRONT DOOR SERVICE HOLE COVER LH

- (a) Remove the 6 screws and door trim bracket.
- (b) Remove the service hole cover.

NOTICE:

Remove the remaining tape on the body side.

- (c) Remove the 2 screws and front door reinforcement.

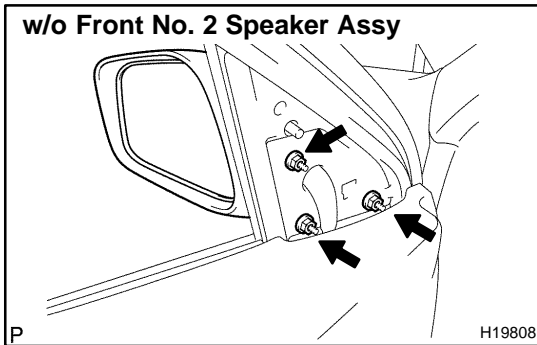
**9. REMOVE OUTER REAR VIEW MIRROR ASSY LH**

- (a) Disconnect the outer mirror connector.
- (b) w/o Front No.2 speaker assembly:
Remove the outer mirror assembly.
 - (1) Remove the 3 nuts and outer mirror assembly.
- (c) w/ Front No.2 speaker assembly:
Remove the outer mirror assembly.
 - (1) Disconnect the speaker connector.
 - (2) Remove the 2 nuts and front No.2 speaker.
 - (3) Remove the nut and outer mirror.

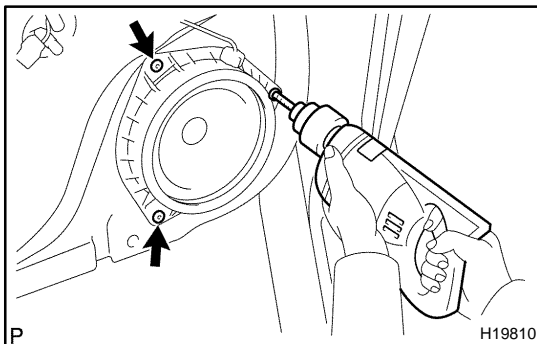
**10. REMOVE FRONT DOOR BELT MOULDING ASSY LH
(See page 76-8)****11. REMOVE FRONT NO.1 SPEAKER ASSY**

- (a) Disconnect the speaker connector.
- (b) Using a drill of less than \varnothing 4 mm (0.16 in.), drill out the rivet heads and remove the speaker.
- (c) Gently and vertically put the drill onto the rivet, and cut the rivet flanges.

NOTICE:

- **Prizing the hole with a drill can lead to damage to the rivet hole or breaking the drill.**
 - **Be careful with the cut rivet, because it is hot.**
- (d) Even if the flange is taken off, continue drilling and push out the remaining fragments with the drill.
 - (e) Using a vacuum cleaner, remove the drilled rivet and dust from the inside of the door.

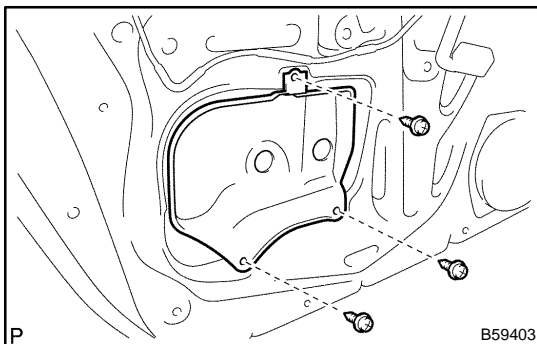
**12. REMOVE FRONT DOOR INSIDE PANEL PLATE LH**

- (a) Remove the 3 screws and front door inside panel plate.

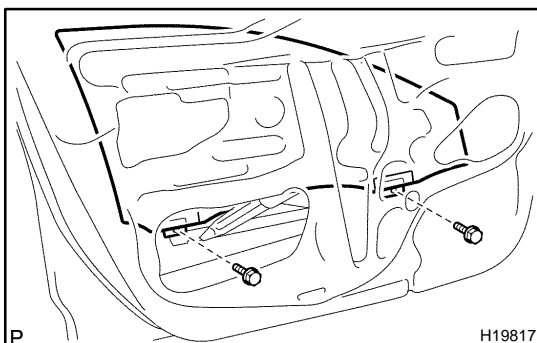
**13. REMOVE FRONT DOOR GLASS SUB-ASSY LH****HINT:**

Insert a shop rag inside the door panel to prevent the glass from being scratched.

- (a) Open the door glass until the bolts appear in the service hole.
- (b) Remove the 2 bolts and door glass.

NOTICE:

Do not damage the door glass.

HINT:

Pull the glass upward to remove it.

14. REMOVE FRONT DOOR GLASS RUN LH

- (a) Remove the front door glass run.

15. REMOVE FRONT DOOR WINDOW REGULATOR SUB-ASSY LH (W/O POWER WINDOW)

- (a) Loosen the 6 bolts.

NOTICE:

When the bolts are removed, the front door window regulator might drop and be deformed.

- (b) Remove the 6 bolts and front door window regulator.

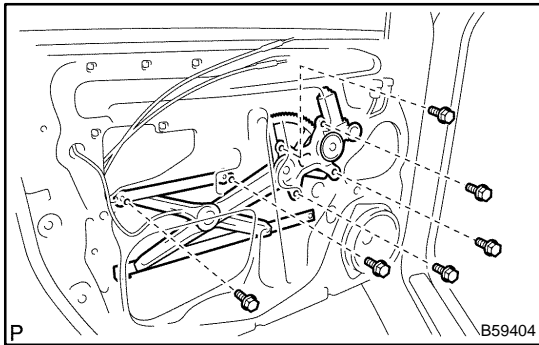

16. REMOVE FRONT DOOR WINDOW REGULATOR SUB-ASSY LH (W/ POWER WINDOW)

- (a) Disconnect the window regulator connector.

- (b) Loosen the 6 bolts.

NOTICE:

When the bolts are removed, the front door window regulator might drop and be deformed.

- (c) Remove the 6 bolts and front door window regulator.

17. REMOVE POWER WINDOW REGULATOR MOTOR ASSY LH (W/ POWER WINDOW)

- (a) Place matchmarks on the window regulator motor bracket and regulator gear.

- (b) Remove the 3 screws and motor.

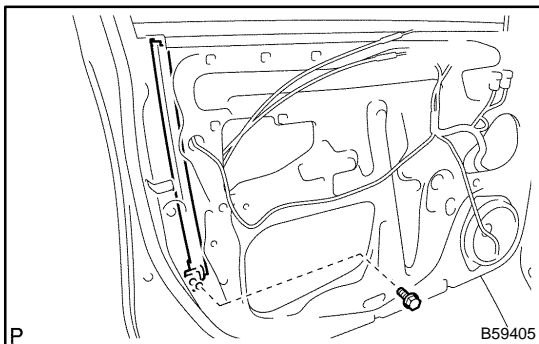

18. REMOVE FRONT DOOR FRAME SUB-ASSY REAR LOWER LH

- (a) Remove the bolt and front door frame rear lower.

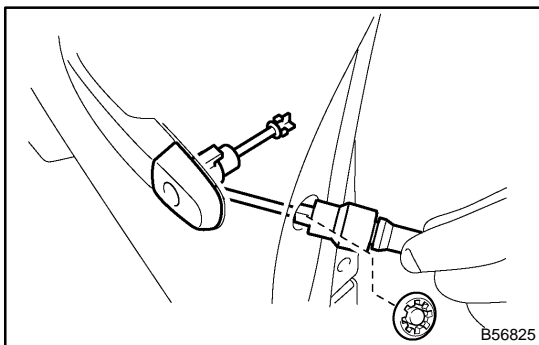

19. REMOVE FRONT DOOR OUTSIDE HANDLE COVER LH

- (a) Remove the hole plug.

- (b) Using a torx wrench (T30), loosen the screw and remove the door outside handle cover with the door lock key cylinder installed.

20. REMOVE FRONT DOOR LOCK ASSY LH (W/O POWER DOOR LOCK)

- (a) Using a torx wrench (T30), remove the 3 screws and door lock assembly.

HINT:

Remove the door lock through the service hole.

- (b) Remove the door lock wire harness packing.

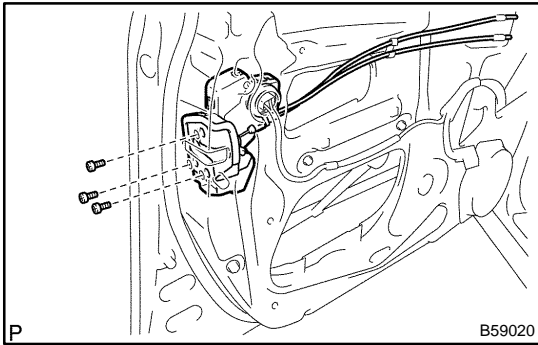

21. REMOVE FRONT DOOR W/MOTOR LOCK ASSY LH (W/ POWER DOOR LOCK)

- (a) Disconnect the power door lock connector.
- (b) Using a torx wrench (T30), remove the 3 screws and the power door lock assembly.

HINT:

Remove the door lock through the service hole.

- (c) Remove the door lock wire harness packing.

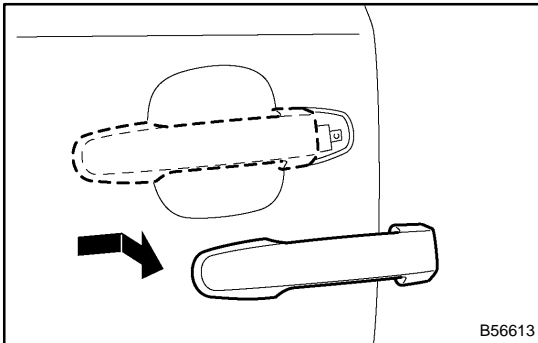

22. REMOVE FRONT DOOR HANDLE ASSY OUTSIDE LH

- (a) Pushing the outside handle in the arrow mark direction in the illustration, remove the outside handle.

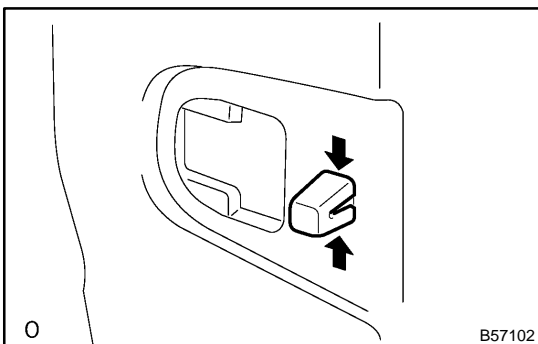

23. REMOVE FRONT DOOR OUTSIDE HANDLE FRAME SUB-ASSY LH

- (a) Using a torx wrench (T30), loosen the screw.
- (b) Using pliers, disengage the clips and remove the door outside handle frame, as shown in the illustration.

NOTICE:

Be sure to remove the outside handle together with the clips, because the clips will be damaged if the clips remain attached to the door panel.

24. REMOVE FRONT DOOR WEATHERSTRIP LH

- (a) Remove the door panel side bolt and disconnect the front door check.
- (b) Using a screwdriver, remove the weatherstrip.

HINT:

Tape the screwdriver tip before use.

25. INSTALL FRONT DOOR WEATHERSTRIP LH

- (a) Install the weatherstrip.
- (b) Install the front door check assembly with the door panel side bolt.

Torque: 5.5 N·m (56 kgf·cm, 49 in.-lbf)

26. INSTALL FRONT DOOR OUTSIDE HANDLE FRAME SUB-ASSY LH

- (a) Using a torx wrench (T30), install the outside handle.

Torque: 4.0 N·m (41 kgf·cm, 35 in.-lbf)

27. INSTALL FRONT DOOR LOCK ASSY LH (W/O POWER DOOR LOCK)

- (a) Install a new door lock wire harness packing.
- (b) Apply MP grease to the sliding and rotating parts of the door lock.
- (c) Apply adhesive to the 3 screws.

Part No. 08833-00070, THREE BOND 1324 or equivalent

- (d) Using a torx wrench (T30), install the door lock assembly with the 3 screws.

Torque: 5.0 N·m (51 kgf·cm, 44 in.-lbf)

28. INSTALL FRONT DOOR W/MOTOR LOCK ASSY LH (W/ POWER DOOR LOCK)

- (a) Install a new door lock wire harness packing.

NOTICE:

- If reusing the removed lock with front door motor, the packing in the connecting part should be replaced with a new one.
 - Be careful that no grease and dirt will stick to the packing surface in the connecting part.
 - Reusing the removed packing or using a damaged packing will cause water to penetrate through the connecting part, and it will result in a malfunction of the door lock.
- (b) Insert the outside handle link into the lock assembly with front door motor, and then set it to the door panel.

NOTICE:

Make sure that the outside handle link is securely engaged with the lock assembly.

- (c) Apply MP grease to the sliding and rotating parts of the door lock.
 (d) Apply adhesive to the 3 screws.

Part No. 08833-00070, THREE BOND 1324 or equivalent.

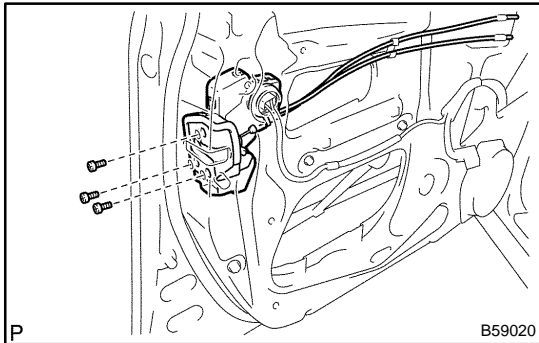

- (e) Using a torx wrench (T30), install the front door lock assembly with the 3 screws.

Torque: 5.0 N·m (51 kgf·cm, 44 in.-lbf)

- (f) Connect the power door lock connector.

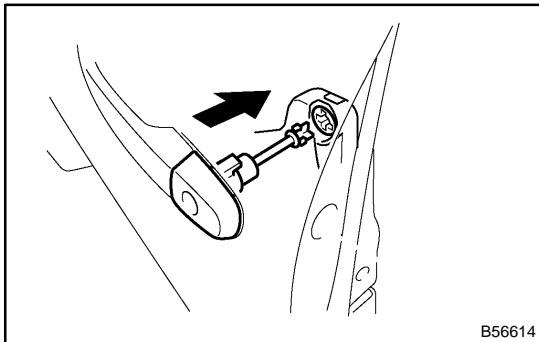
**29. INSTALL FRONT DOOR OUTSIDE HANDLE COVER LH**

- (a) Using a torx wrench (T30), install the door outside handle cover with the screw.

Torque: 4.0 N·m (41 kgf·cm, 35 in.-lbf)

- (b) Install the hole plug.

30. INSTALL FRONT DOOR FRAME SUB-ASSY REAR LOWER LH

- (a) Install the front door frame rear lower with the bolt.

Torque: 6.2 N·m (63 kgf·cm, 55 in.-lbf)

31. INSTALL POWER WINDOW REGULATOR MOTOR ASSY LH (W/ POWER WINDOW)

- (a) Align the matchmarks on the regulator motor bracket and regulator gear.
 (b) Install the 3 screws.

Torque: 5.4 N·m (55 kgf·cm, 48 in.-lbf)

HINT:

Never rotate the motor to the down direction until the window glass installation has done.

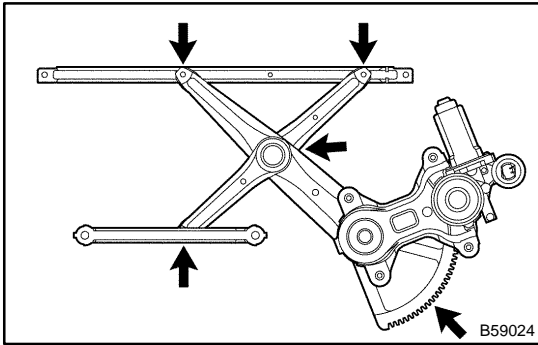

32. INSTALL FRONT DOOR WINDOW REGULATOR SUB-ASSY LH (W/ POWER WINDOW)

- (a) Apply MP grease to the sliding and rotating parts of the window regulator.

NOTICE:

Do not apply grease to the spring of the window regulator.

- (b) Apply the window regulator to the 6 regulator installation holes on the front door panel, temporarily install the window regulator with the 6 installation bolts.
- (c) Tighten the 6 bolts.

Torque: 8.0 N·m (82 kgf·cm, 71 in.-lbf)

- (d) Connect the window regulator connector.

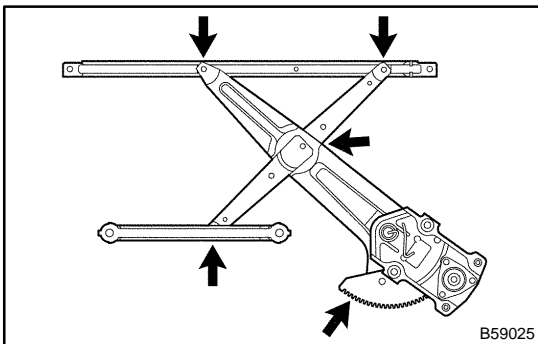

33. INSTALL FRONT DOOR WINDOW REGULATOR SUB-ASSY LH (W/O POWER WINDOW)

- (a) Apply MP grease to the sliding and rotating parts of the window regulator.

NOTICE:

Do not apply grease to the spring of the window regulator.

- (b) Install the front door window regulator with the 6 bolts.

Torque: 8.0 N·m (82 kgf·cm, 71 in.-lbf)

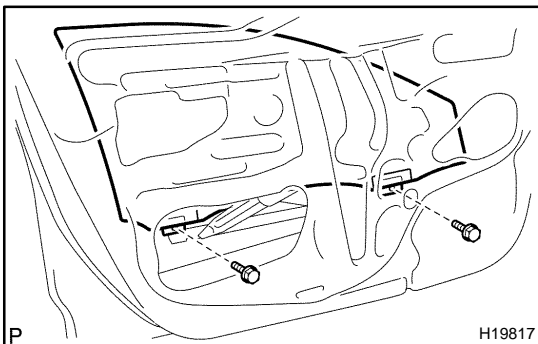

34. INSTALL FRONT DOOR GLASS SUB-ASSY LH (W/ POWER WINDOW)

NOTICE:

Do not damage the door glass.

- (a) Put the door glass in the door panel carefully.
- (b) Install the door glass to the window regulator with the 2 bolts.

Torque: 8.0 N·m (82 kgf·cm, 71 in.-lbf)

- (c) Inspect the power window operation.

HINT:

When the installation point of the front door glass does not match, adjust the regulator position in the manual operation.

- (1) Connect the power window switch to the wire harness and turn the ignition switch ON.
- (2) Repeat UP and DOWN operation several times in the manual operation.

35. INSPECT POWER WINDOW FUNCTION (W/ POWER WINDOW) (See page 70-4)

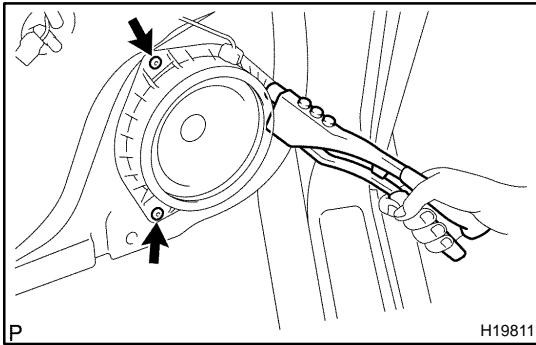

36. INSTALL FRONT NO.1 SPEAKER ASSY

- (a) Install the front speaker to the door.
- (b) Using an air riveter or hand riveter, install the front speaker.

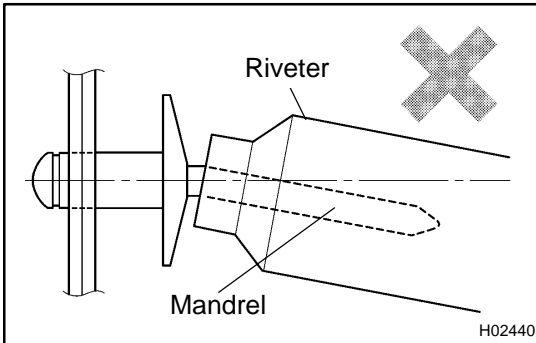

NOTICE:

- Do not prize a riveter, because the riveter will be damaged, and the mandrel will be bent.

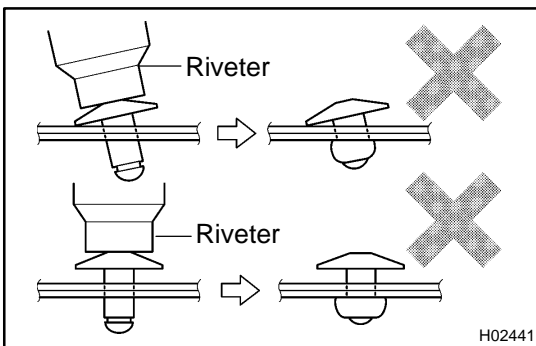

- Do not tilt the riveter when removing the rivet, because the materials are not tightened firmly.

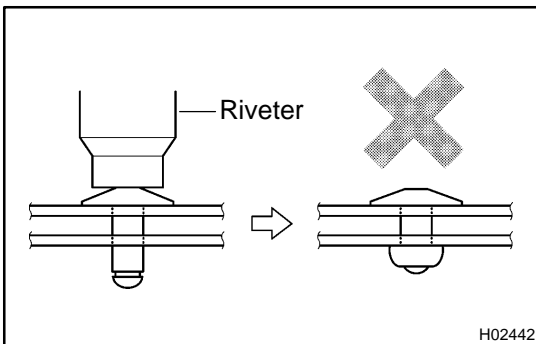

- Install the rivet while attaching the materials, because they are not tightened firmly.
- (c) Connect the speaker connector.

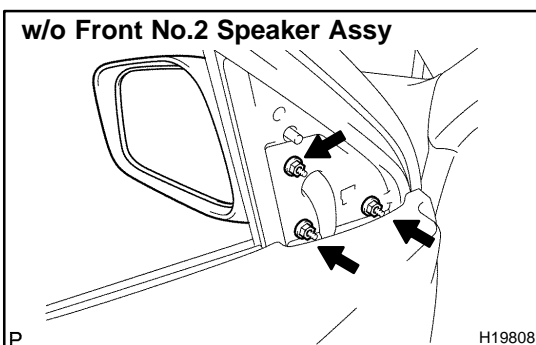

37. INSTALL OUTER REAR VIEW MIRROR ASSY LH

- (a) w/o Front No.2 speaker assembly:
 - Install the outer mirror assembly.
 - (1) Install the outer mirror with the 3 nuts.

Torque: 8.0 N·m (82 kgf·cm, 71 in.-lbf)
- (b) w/ Front No.2 speaker assembly:
 - Install the outer mirror assembly.
 - (1) Temporarily install the outer mirror with the nut.
 - (2) Temporarily install the front No.2 speaker with the 2 nuts.

(3) Tighten the 3 nuts.

Torque: 8.0 N·m (82 kgf·cm, 71 in.-lbf)

(4) Connect the speaker connector.

(c) Connect the outer mirror connector.

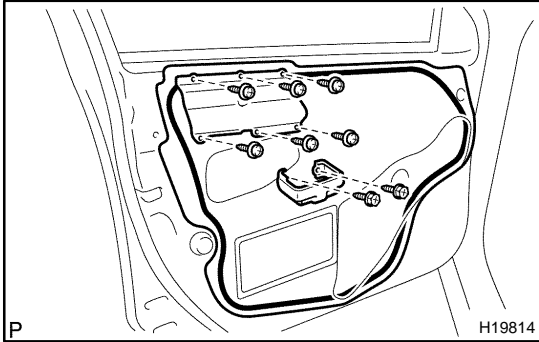

38. INSTALL FRONT DOOR SERVICE HOLE COVER LH

(a) Install the front door reinforcement with the 6 screws.

(b) Install a new service hole cover to the door panel.

HINT:

- When installing the service hole cover, pull out the links and connectors through the service hole cover.
- There should be no wrinkles or folds after attaching the service hole cover.
- After attaching the service hole cover, sealing condition should be confirmed.

(c) Install the door trim board bracket with the 2 screws.

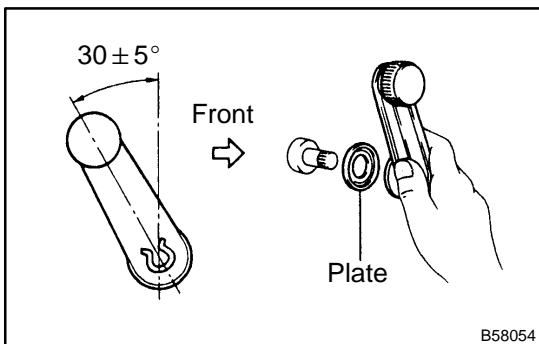

39. INSTALL FRONT DOOR WINDOW REGULATOR HANDLE ASSY (W/O POWER WINDOW)

(a) Install the regulator handle with the snap ring.

HINT:

With the door window fully closed, install the plate and regulator handle with the snap ring as shown in the illustration.