

VOLTAGE INVERTER ASSY

REPLACEMENT

670EQ-01

HINT:

COMPONENTS: See page 67-2

1. DISCONNECT BATTERY NEGATIVE TERMINAL (See page 72-2)
2. REMOVE FRONT SEAT (DRIVER SEAT POSITION) (See page 72-2)

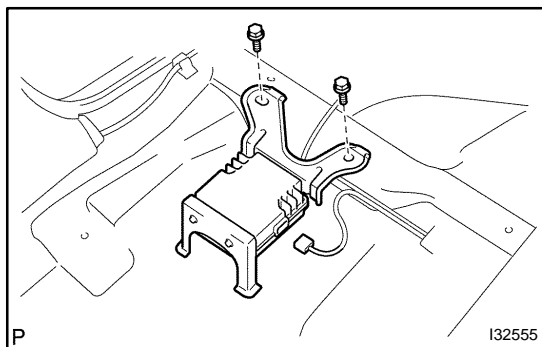

3. REMOVE VOLTAGE INVERTER ASSY

- (a) Remove the 2 bolts.
- (b) Fold the floor carpet to the inside.
- (c) Disconnect the connector.
- (d) Remove the voltage inverter assy.

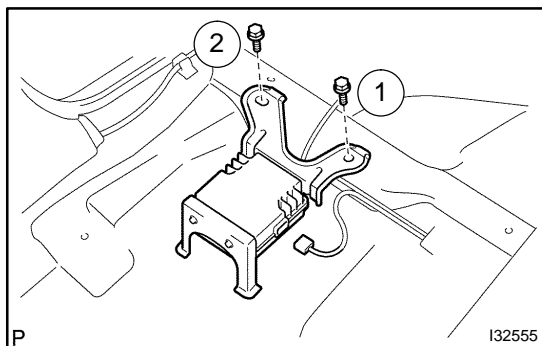

4. INSTALL VOLTAGE INVERTER ASSY

- (a) Install the voltage inverter assy.
- (b) Connect the connector.
- (c) Fold the floor carpet to the inside.
- (d) Tighten the 2 bolts.

Torque: 7.0 N·m (71 kgf·cm, 62 in.-lbf)

NOTICE:

Tighten the bolts in following order shown in the illustration to install the voltage inverter assy.

5. INSTALL FRONT SEAT (DRIVER SEAT POSITION) (See page 72-2)