

WINDSHIELD WIPER MOTOR ASSY REPLACEMENT

66076-01

1. REMOVE WINDSHIELD WIPER ARM COVER

2. REMOVE FR WIPER ARM RH

- (a) Operate the wiper and stop the windshield wiper motor assy at the automatic stop position.
- (b) Remove a nut and FR wiper arm RH.

3. REMOVE FR WIPER ARM LH

- (a) Remove a nut and FR wiper arm LH.

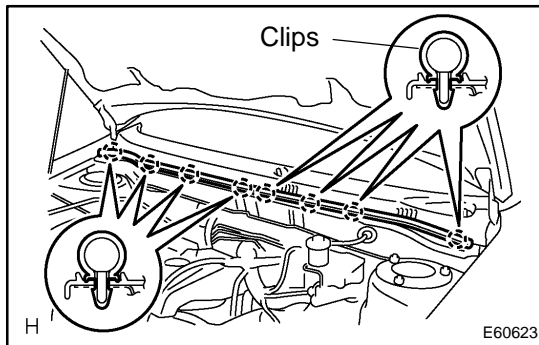

4. REMOVE HOOD TO COWL TOP SEAL

- (a) Using a clipremover, disengage the meshing of 8 clips and remove the hood to cowl top seal.

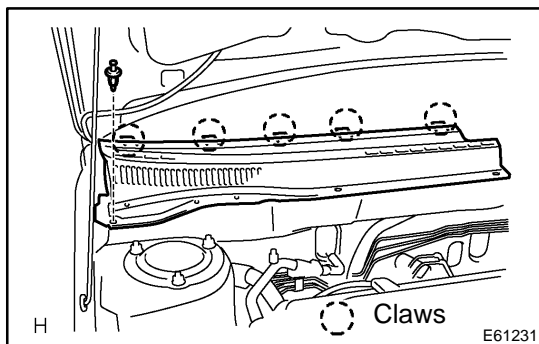

5. REMOVE COWL TOP VENTILATOR LOUVER RH

- (a) Remove a clip and release the 5 claws, and remove the cowl top ventilator louver RH.

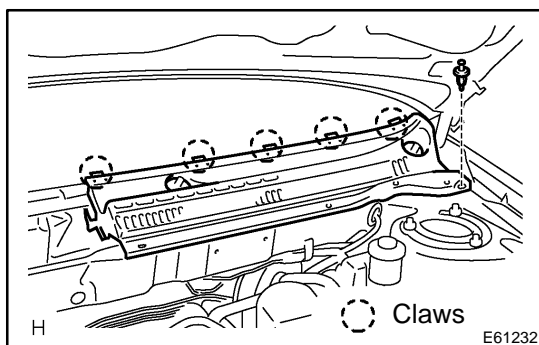

6. REMOVE COWL TOP VENTILATOR LOUVER LH

- (a) Remove a clip and release the 5 claws, and remove the cowl top ventilator louver LH.

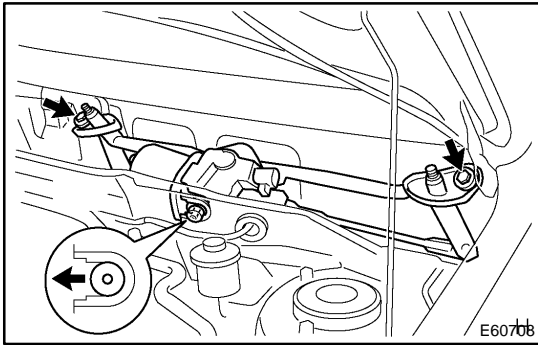
**7. REMOVE WINDSHIELD WIPER LINK ASSY**

- (a) Disconnect the connector.
- (b) Remove the 2 bolts.
- (c) Slide the wiper link assy to vehicle's passengers side. Disengage the meshing of the rubber pin and remove the wiper link assy.

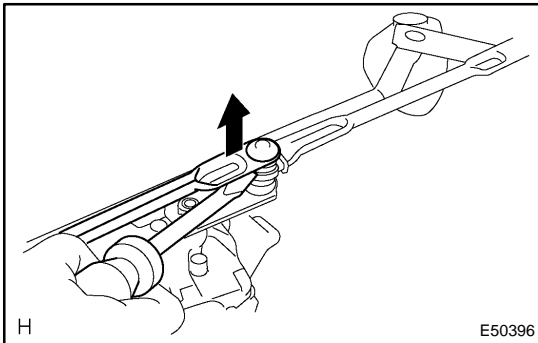
**8. REMOVE WINDSHIELD WIPER MOTOR ASSY**

- (a) Using a screwdriver and disengage the meshing of 2 rods at the clank arm pivot of the windshield wiper motor assy.

HINT:

Tape the screwdriver tip before use.

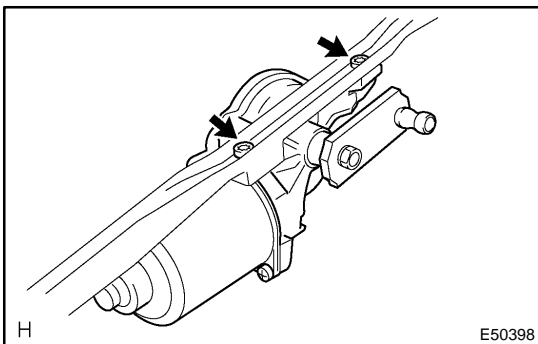
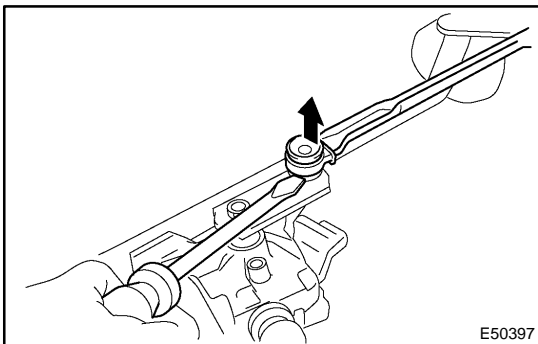

- (b) Remove 2 torx bolts and windshield wiper motor assy.

9. INSTALL WINDSHIELD WIPER MOTOR ASSY

- (a) Apply MP grease to the clank arm pivot of the windshield wiper motor assy.
- (b) Using 2 torx bolts, install the windshield wiper motor assy to the windshield wiper link assy.

Torque: 7.5 N·m (76 kgf·cm, 66 in.-lbf)

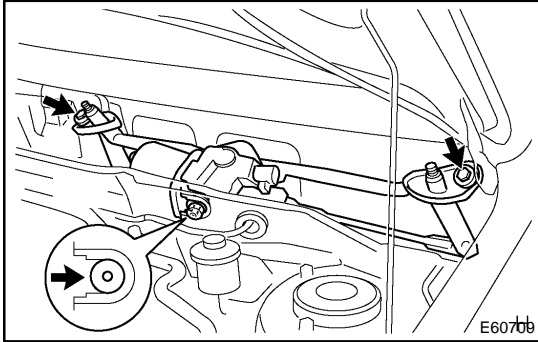
**10. INSTALL WINDSHIELD WIPER LINK ASSY**

- (a) Install the meshing of the rubber pin.
- (b) Install the windshield wiper link assy. with the 2 bolts.

Torque: 5.5 N·m (56 kgf·cm, 49 in.-lbf)

- (c) Connect the connector.

11. INSTALL FR WIPER ARM LH

- (a) Operate the wiper, and stop the windshield wiper motor assy at the automatic stop position.

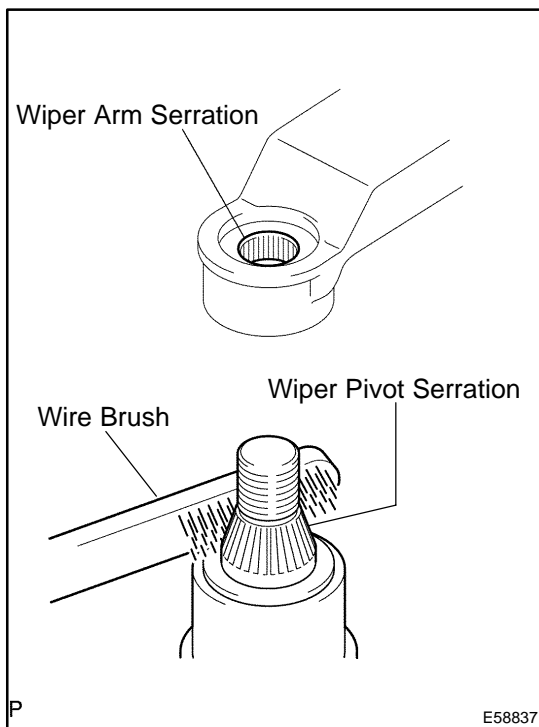

- (b) Scrape off the serration part of the wiper arm with a round file or equivalent.

- (c) Clean the wiper pivot serration with the wire brush.

- (d) Install the front wiper arm LH with a nut to the position shown in the illustration.

Torque: 20.5 N·m (209 kgf·cm, 15 ft·lbf)

HINT:

Hold down the arm hinge with hand to fasten a nut.

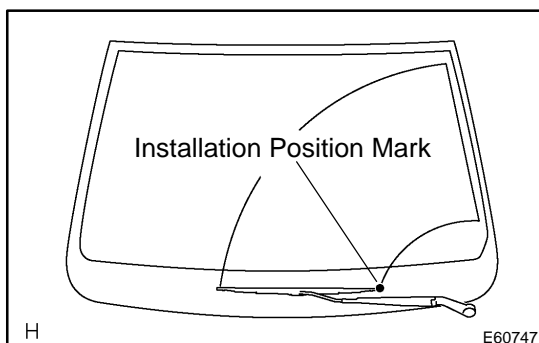

12. INSTALL FR WIPER ARM RH

- (a) Scrape off the serration part of the wiper arm with a round file or equivalent.
- (b) Clean the wiper pivot serration with the wire brush.
- (c) Install the front wiper arm RH with a nut at the position shown in the illustration.

Torque: 20.5 N·m (209 kgf·cm, 15 ft·lbf)

HINT:

Hold down the arm hinge with hand to fasten a nut.

- (d) Operate the wiper while running the water or the washer fluid over the window, and check the wiping condition and that the rear wiper does not hit against the vehicle body.

