

DISPOSAL

HINT:

When scrapping vehicle equipped with an SRS or disposing of a instrument panel passenger airbag assy, always first deploy the airbag in accordance with the procedure described below. If any abnormality occurs with the airbag deployment, contact the SERVICE DEPT. of the TOYOTA MOTOR SALES, U.S.A., INC.

CAUTION:

- Never dispose of a instrument panel passenger airbag assy which has an undeployed airbag.
- The airbag produces a sizeable exploding sound when it deploys, so perform the operation out-of-doors and where it will not create a nuisance to nearby residents.

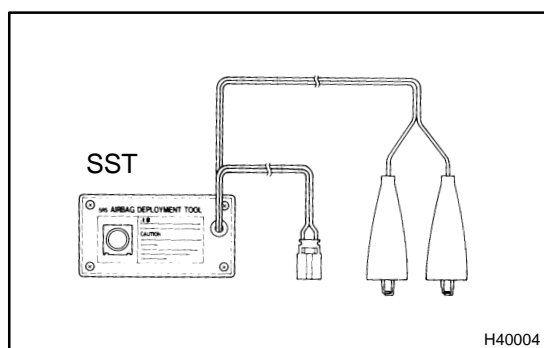

- When deploying the airbag, always use the specified SST (SRS Airbag Deployment Tool). Perform the operation in a place away from electrical noise.
- When deploying an airbag, perform the operation at least 10 m (33 ft) away from the instrument panel passenger airbag assy.
- The instrument panel passenger airbag assy is very hot when the airbag is deployed, so leave it alone for at least 30 minutes after deployment.
- Use gloves and safety glasses when handling a instrument panel passenger airbag assy with the deployed airbag.
- Always wash your hands with water after completing the operation.
- Do not apply water, etc. to a instrument panel passenger airbag assy with the deployed airbag.

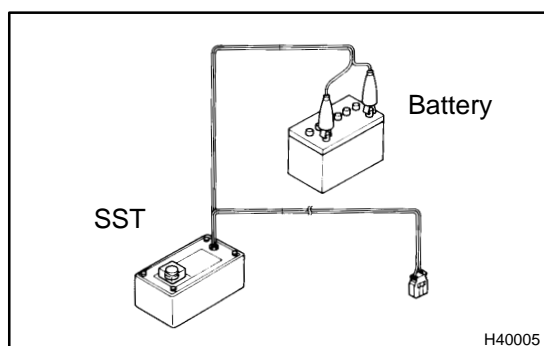

1. DISPOSE INSTRUMENT PANEL PASSENGER AIR BAG ASSY (WHEN SCRAPPING VEHICLE DEPLOYMENT METHOD)

HINT:

Have a battery ready as the power source to deploy the airbag.

- (a) Check functioning of the SST (See step 1-(a) on page 60-14).

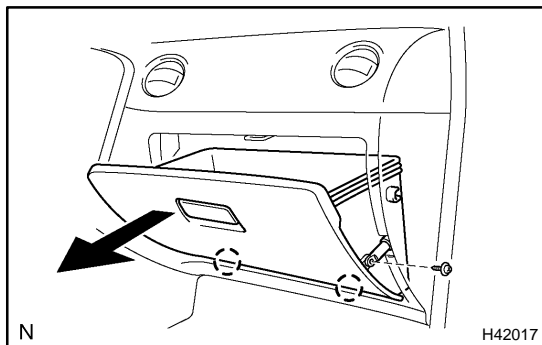

(b) Remove the screw and glove compartment door assy.

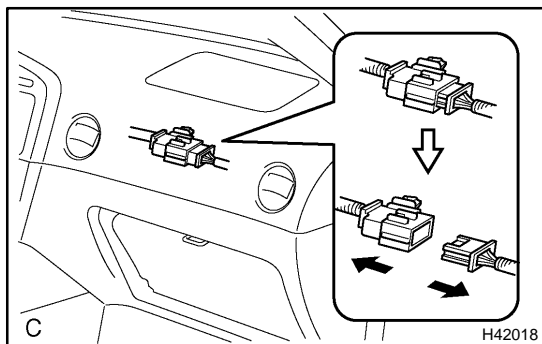

(c) Disconnect the instrument panel passenger airbag connector.

NOTICE:

When handling the airbag connector, take care not to damage the airbag wire harness.

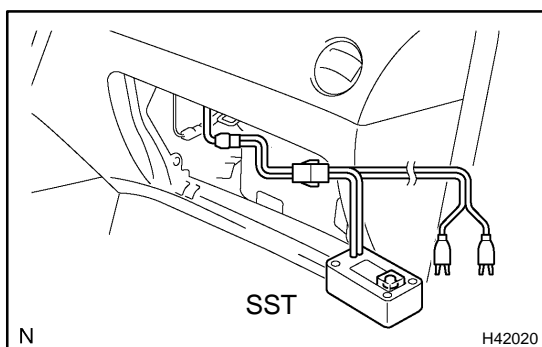

(d) Install the SST.

- (1) Connect the connector of the SST to the instrument panel passenger airbag assy connector.

SST 09082-00700, 09082-00780

NOTICE:

To avoid damaging the SST connector and wire harness, do not lock the secondary lock of the twin lock.

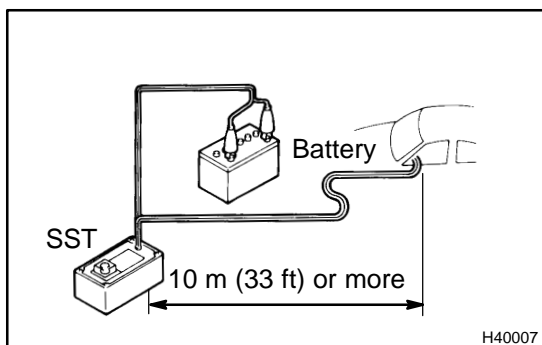

- (2) Move the SST to at least 10 m (33 ft) away from the front of the vehicle.

- (3) Close all the doors and windows of the vehicle.

NOTICE:

Take care not to damage the SST wire harness.

- (4) Connect the red clip of the SST to the battery positive (+) terminal and the black clip to the negative (-) terminal.

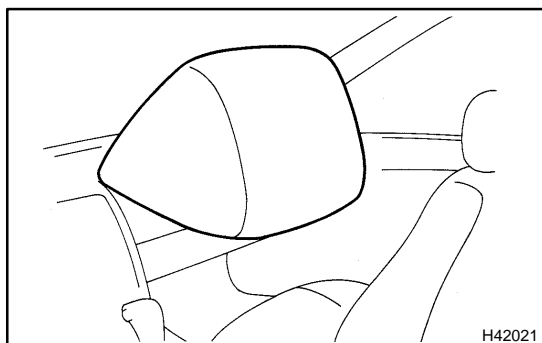

(e) Deploy the airbag.

- (1) Check that no one is inside the vehicle or within 10 m (33 ft) area around the vehicle.

- (2) Press the SST activation switch and deploy the airbag.

HINT:

The airbag deploys simultaneously as the LED of the SST activation switch lights up.

(f) Dispose the instrument panel passenger airbag assy.

CAUTION:

- The instrument panel passenger airbag assy is very hot when the airbag is deployed, so leave it alone for at least 30 minutes after deployment.
- Use gloves and safety glasses when handling a instrument panel passenger airbag assy with the deployed airbag.
- Always wash your hands with water after completing the operation.
- Do not apply water, etc. to a instrument panel passenger airbag assy with the deployed airbag.
- When moving a vehicle for scrapping which has a instrument panel passenger airbag assy with the deployed airbag, use gloves and safety glasses.

HINT:

When scrapping a vehicle, deploy the airbag and scrap the vehicle with the instrument panel passenger airbag assy still installed.

2. DISPOSE INSTRUMENT PANEL PASSENGER AIR BAG ASSY (WHEN DISPOSING OF AIRBAG ASSEMBLY DEPLOYMENT METHOD)

NOTICE:

- When disposing of the instrument panel passenger airbag assy only, never use the customer's vehicle to deploy the airbag.
- Be sure to follow the procedure given below when deploying the airbag.

HINT:

Have a battery ready as the power source to deploy the airbag.

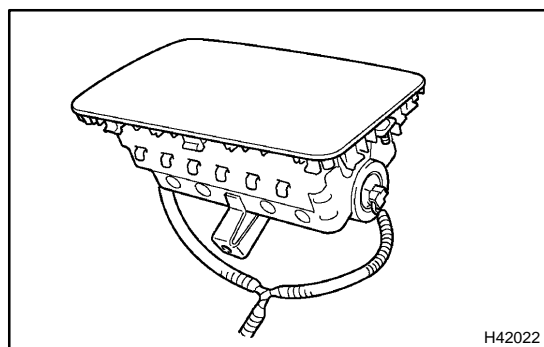

- (a) Remove the instrument panel passenger airbag assy (See page 60-25).

CAUTION:

- When removing the instrument panel passenger airbag assy, work must be started 90 seconds after the ignition switch is turned to the "LOCK" position and the negative (-) terminal cable is disconnected from the battery.
- Store the instrument panel passenger airbag assy with the airbag deployment side facing upward.

- (b) Using a service-purpose wire harness for the vehicle, tie down the instrument panel passenger airbag assy to the tire.

**Wire harness: Stripped wire harness section
1.25 mm² or more (0.0019 in.² or more)**

CAUTION:

If the instrument panel passenger airbag assy is tied down with too thin wire harness, it may snap. This is highly dangerous. Always use a wire harness which is at least 1.25 mm² (0.0019 in.²).

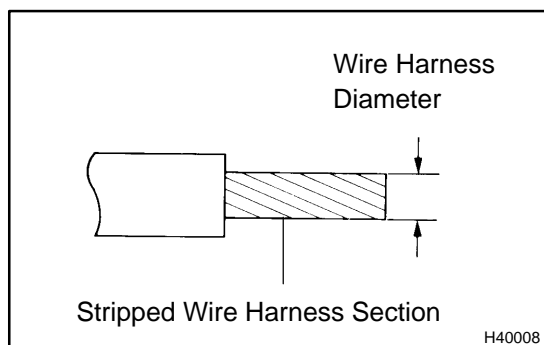

HINT:

To calculate the square of the stripped wire harness section:

$$\text{Square} = 3.14 \times (\text{Diameter})^2 \text{ divided by } 4$$

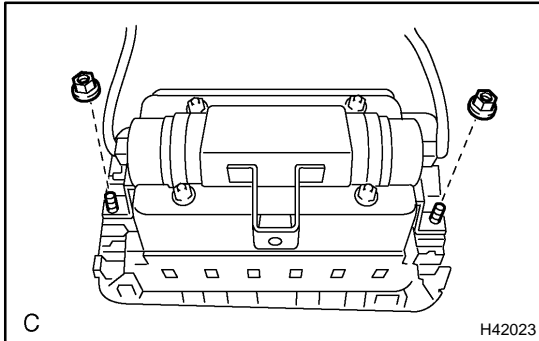

- (1) Install the 2 nuts to the instrument panel passenger airbag assy.

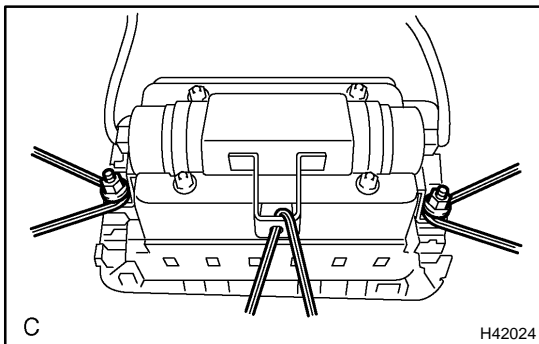

- (2) Wind the wire harness around the brackets, as shown in the illustration.
- (3) Position the instrument panel passenger airbag assy inside the tire with the airbag deployment side facing inside.

Tire size: Must exceed the following dimensions–

Width: 185 mm (7.28 in.)

Inner diameter: 360 mm (14.17 in.)

CAUTION:

- **Make sure that the wire harness is tight. It is very dangerous if looseness in the wire harness results in the instrument panel passenger airbag assy coming free due to the shock from the airbag deploying.**
- **Always tie down the instrument panel passenger airbag assy with the airbag deployment side facing inside.**

NOTICE:

The tire will be marked by the airbag deployment, so use a redundant tire.

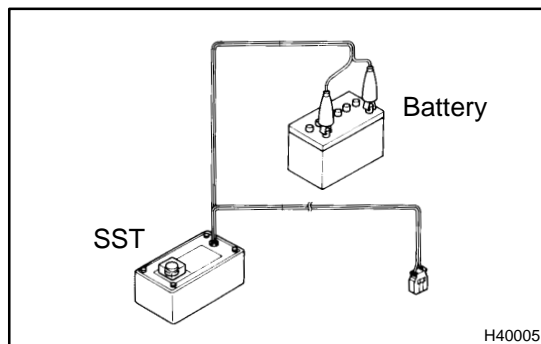
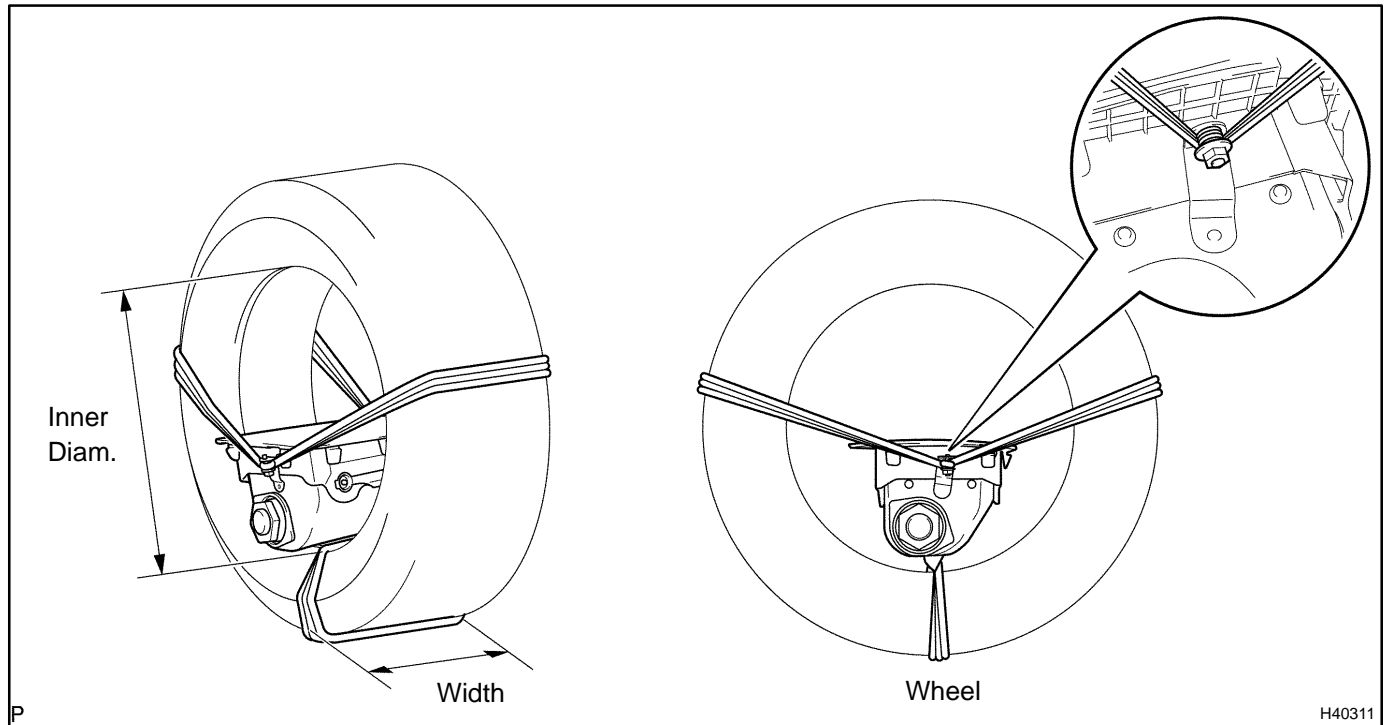

- (c) Check functioning of the SST (See step 1-(a) on page 60-14).

SST 09082-00700

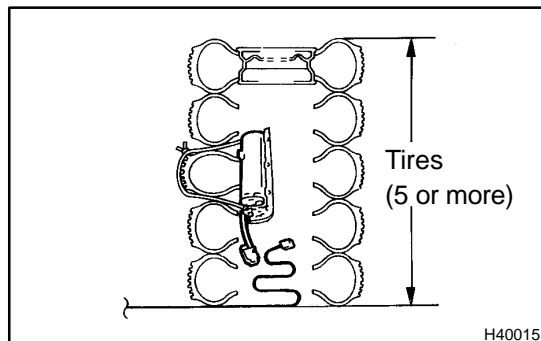

- (d) Place tires.

- (1) Place at least 2 tires under the tire to which the instrument panel passenger airbag assy is tied.
- (2) Place at least 2 tires over the tire to which the instrument panel passenger airbag assy is tied. The top tire should have the wheel installed.

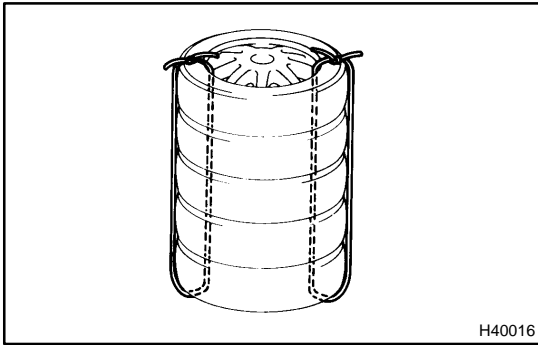

- (3) Tie the tires together with 2 wire harness.

CAUTION:

Make sure that the wire harness is tight. It is very dangerous if loose wire harness result in the tires coming free due to the shock from the airbag deploying.

HINT:

Place the SST connector and wire harness inside tires. Secure at least 1 m (3 ft) of slack for the wire harness.

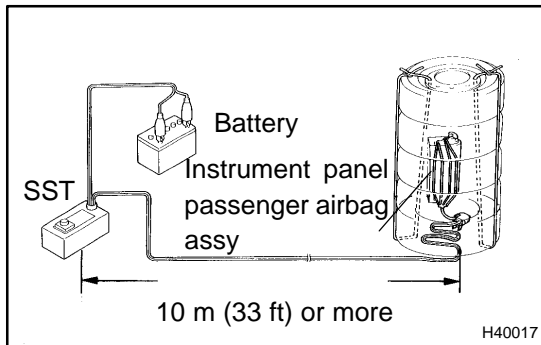

- (e) Install the SST.

- (1) Connect the connectors of the 2 SST to the instrument panel passenger airbag assy connector.

SST 09082-00700, 09082-00780

NOTICE:

To avoid damaging the SST connector and wire harness, do not lock the secondary lock of the twin lock.

- (f) Deploy the airbag.

- (1) Connect the SST red clip to the battery positive (+) terminal and the black clip to the battery negative (-) terminal.
- (2) Check that no one is within 10 m (33 ft) area around the tire which the instrument panel passenger airbag assy is tied to.
- (3) Press the SST activation switch and deploy the airbag.

HINT:

The airbag deploys simultaneously as the LED of the SST activation switch lights up.

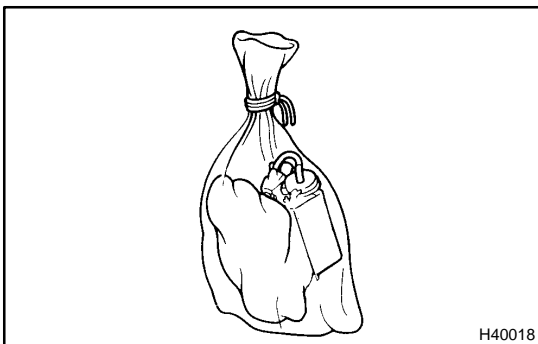

- (g) Dispose the instrument panel passenger airbag assy.

CAUTION:

- **The instrument panel passenger airbag assy is very hot when the airbag is deployed, so leave it alone for at least 30 minutes after deployment.**
- **Use gloves and safety glasses when handling a instrument panel passenger airbag assy with the deployed airbag.**
- **Always wash your hands with water after completing the operation.**
- **Do not apply water, etc. to a instrument panel passenger airbag assy with the deployed airbag.**
 - (1) Remove the instrument panel passenger airbag assy from the tire.
 - (2) Place the instrument panel passenger airbag assy in a vinyl bag, tie the end tightly and dispose of it in the same way as other general parts.