

DISPOSAL

HINT:

When scrapping vehicle equipped with an SRS or disposing of a horn button assy, always first deploy the airbag in accordance with the procedure described below. If any abnormality occurs with the airbag deployment, contact the SERVICE DEPT. of TOYOTA MOTOR SALES, U.S.A., INC.

CAUTION:

- Never dispose of a horn button assy, which has an un-deployed airbag.
- The airbag produces a sizeable exploding sound when it deploys, so perform the operation out-of-doors and where it will not create a nuisance to nearby residents.

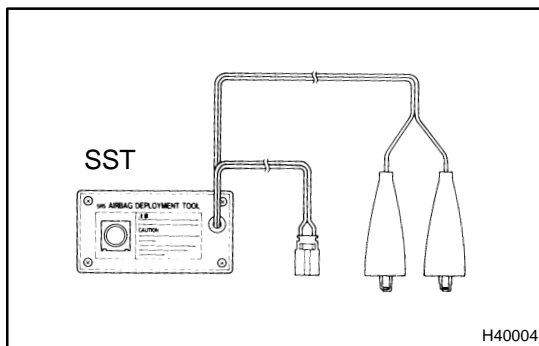

- When deploying the airbag, always use the specified SST (SRS Airbag Deployment Tool). Perform the operation in a place away from electrical noise.
- When deploying an airbag, perform the operation at least 10 m (33 ft) away from the horn button assy.
- The horn button assy is very hot when the airbag is deployed, so leave it alone for at least 30 minutes after deployment.
- Use gloves and safety glasses when handling a horn button assy with the deployed airbag.
- Always wash your hands with water after completing the operation.
- Do not apply water, etc. to a horn button assy with the deployed airbag.

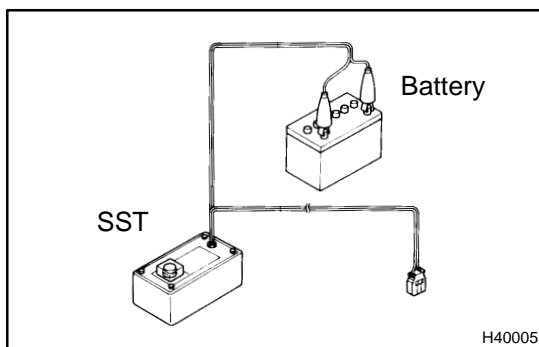

1. DISPOSE HORN BUTTON ASSY (WHEN SCRAPPING VEHICLE DEPLOYMENT METHOD)

HINT:

Have a battery ready as the power source to deploy the airbag.

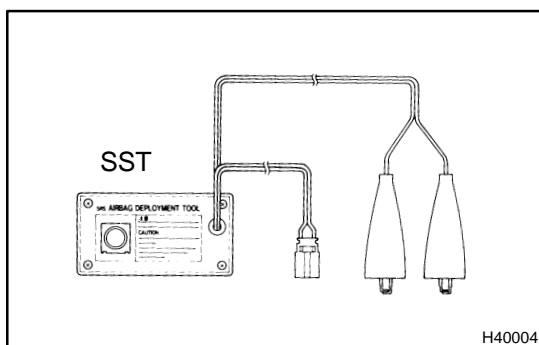

(a) Check functioning of the SST.

CAUTION:

When deploying the airbag, always use the specified SST: SRS Airbag Deployment Tool.

SST 09082-00700

SUPPLEMENTAL RESTRAINT SYSTEM - HORN BUTTON ASSY

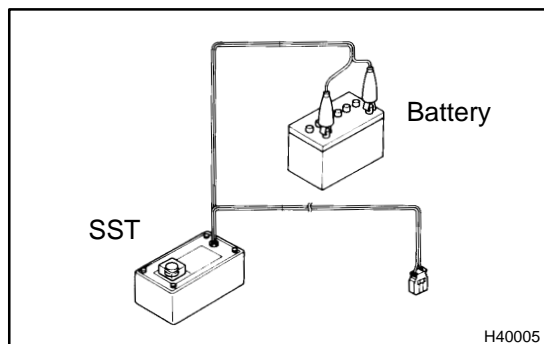

- (1) Connect the SST to the battery.
Connect the red clip of the SST to the battery positive (+) terminal and the black clip to the battery negative (-) terminal.

HINT:

Do not connect the yellow connector which will be connected with the supplemental restraint system.

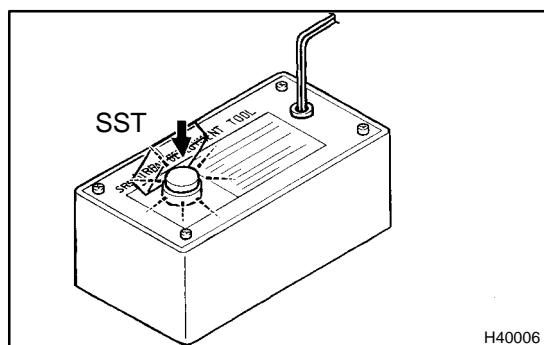

- (2) Check functioning of the SST.
Press the SST activation switch, and check that the LED of the SST activation switch lights up.

CAUTION:

If the LED lights up when the activation switch is not being pressed, SST malfunction is probable, so definitely do not use the SST.

- (3) Disconnect the SST from the battery.

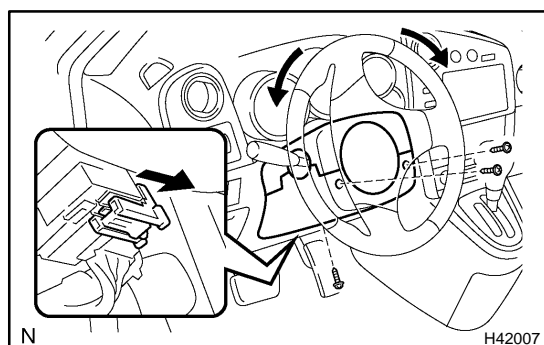

- (b) Install the SST.

CAUTION:

Check that there is no looseness in the steering wheel and horn button assy.

- (1) While turning the steering wheel right / left, remove the 3 screws and steering column cover.
- (2) Disconnect the airbag connector of the spiral cable.

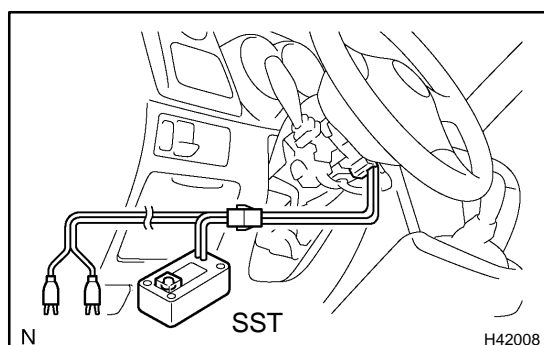

- (3) Connect the connectors of the 2 SST to the airbag connector of the spiral cable back side.

SST 09082-00700, 09082-00780

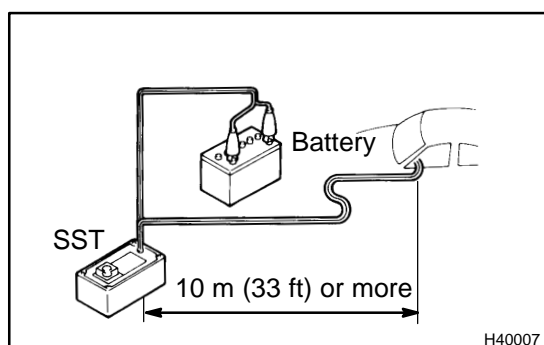

- (4) Move the SST at least 10 m (33 ft) away from the front of the vehicle.
- (5) Close all the doors and windows of the vehicle.

NOTICE:

Take care not to damage the SST wire harness.

- (6) Connect the red clip of the SST to the battery positive (+) terminal and the black clip to the negative (-) terminal.

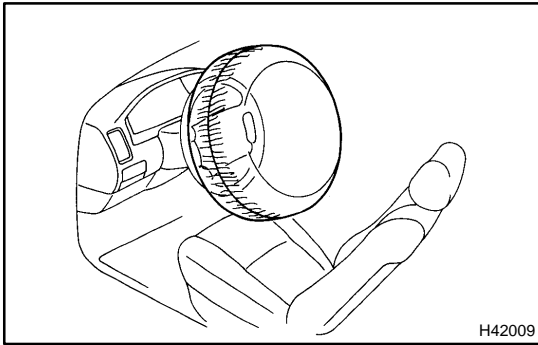

- (c) Deploy the airbag.
- (1) Confirm that no one is inside the vehicle or within 10 m (33 ft) area around the vehicle.
 - (2) Press the SST activation switch and deploy the airbag.

HINT:

The airbag deploys simultaneously as the LED of the SST activation switch lights up.

- (d) Dispose the horn button assy (with airbag).

CAUTION:

- The horn button assy is very hot when the airbag is deployed, so leave it alone for at least 30 minutes after deployment.
- When moving a vehicle for scrapping which has a horn button assy with deployed airbag, use gloves and safety glasses.
- Use gloves and safety glasses when handling a horn button assy with the deployed airbag.
- Always wash your hands with water after completing the operation.
- Do not apply water, etc. to a horn button assy with the deployed airbag.

HINT:

When scrapping a vehicle, deploy the airbag and scrap the vehicle with the horn button assy still installed.

2. DISPOSE HORN BUTTON ASSY (WHEN DISPOSING OF AIRBAG ASSEMBLY DEPLOYMENT METHOD)

NOTICE:

- When disposing of the horn button assy (with airbag) only, never use the customers vehicle to deploy the airbag.
- Be sure to follow the procedure given below when deploying the airbag.

HINT:

Have a battery ready as the power source to deploy the airbag.

- (a) Remove the horn button assy (See page 60-13).

CAUTION:

When storing the horn button assy, keep the upper surface of the pad facing upward.

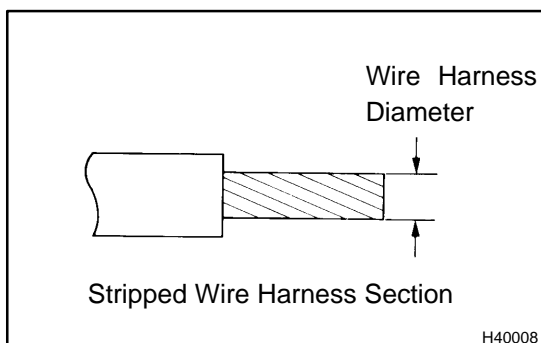

- (b) Using a service-purpose wire harness, tie down the horn button assy to the disc wheel.

**Wire harness: Stripped wire harness section
1.25 mm² or more (0.0019 in². or more)**

CAUTION:

If a wire harness which is too thin or some other thing is used to tie down the horn button assy, it may be snapped by the shock when the airbag is deployed. This is highly dangerous. Always use a wire harness for vehicle use which is at least 1.25 mm² (0.0019 in²).

HINT:

To calculate the square of the stripped wire harness section:

$$\text{Square} = 3.14 \times (\text{Diameter})^2 \text{ divided by } 4$$

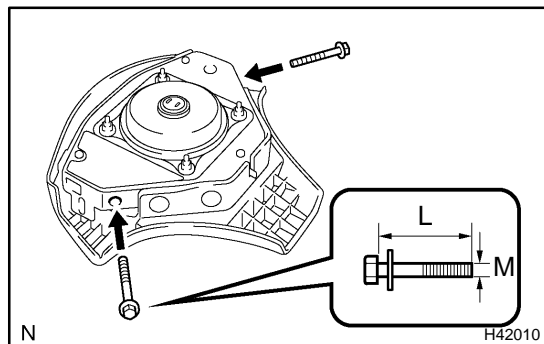

- (1) Install the 2 bolts with washers in the 2 bolt holes in the horn button assy.

Bolt:

L: 35.0 mm (1.378 in.)

M: 6.0 mm (0.236 in.)

Pitch: 1.0 mm (0.039 in.)

NOTICE:

- **Tighten the bolts by hand until the bolts become difficult to turn.**
- **Do not tighten the bolts too much.**

- (2) Connect the connectors of the SST to the horn button assy connectors.

SST 09082-00801 (09082-10801, 09082-30801)

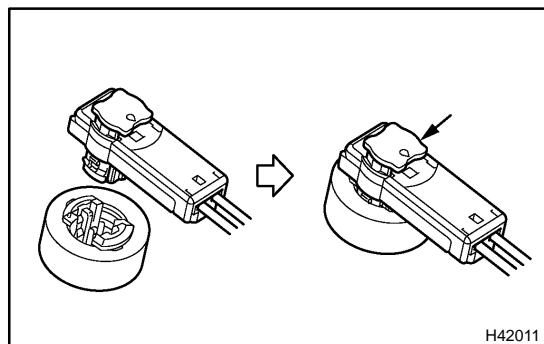

- (3) Using 3 wire harness, wind the wire harness at least 2 times each around the bolts installed on the left and right sides of the horn button assy.

CAUTION:

- **Tightly wind the wire harness around the bolts so that there is no slack.**
- **If there is slack in the wire harness, the horn button assy may come loose due to the shock when the air-bag is deployed. This is highly dangerous.**

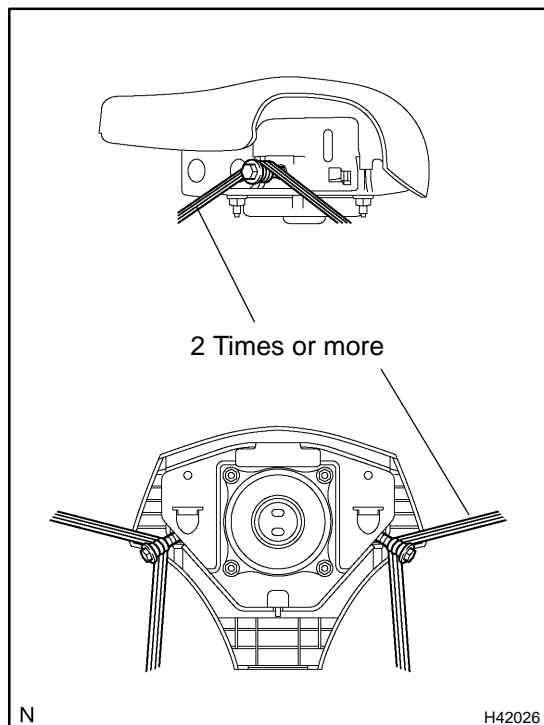

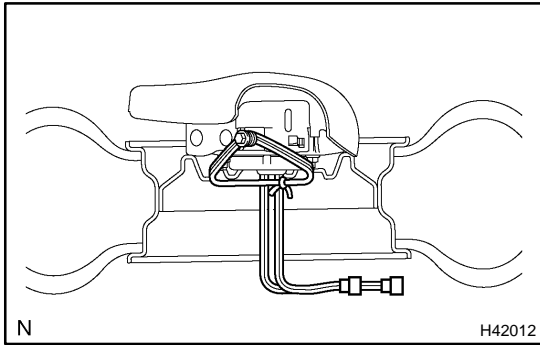

- (4) Face the upper surface of the horn button assy upward. Separately tie the left and right sides of the horn button assy to the disc wheel through the hub nut holes. Position the horn button assy connector so that it hangs downward through a hub hole in the disc wheel.

CAUTION:

- Make sure that the wire harness is tight. It is very dangerous when looseness in the wire harness results in the steering wheel pad coming free through the shock from the airbag deploying.
- Always tie down the horn button assy with the pad side facing upward. It is very dangerous if the horn button assy is tied down with the metal surface facing upward as the wire harness will be cut by the shock from the airbag deploying and the horn button assy will be thrown into the air.

NOTICE:

The disc wheel will be marked by airbag deployment, so when disposing of the airbag use a redundant disc wheel.

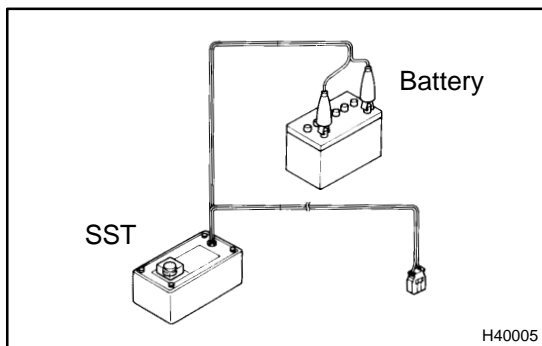

- (c) Check functioning of the SST (See step 1-(a)).

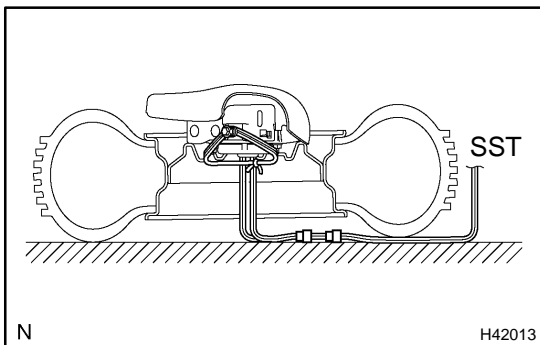

- (d) Install the SST.

CAUTION:

Place the disc wheel on the level ground.

- (1) Connect the connector of the SST to the horn button assy connector.

SST 09082-00700

NOTICE:

To avoid damaging the SST connector and wire harness, do not lock the secondary lock of the twin lock. Also, secure some slack for the SST wire harness inside the disc wheel.

- (2) Move the SST to at least 10 m (33 ft) away from the horn button assy tied down on the disc wheel.

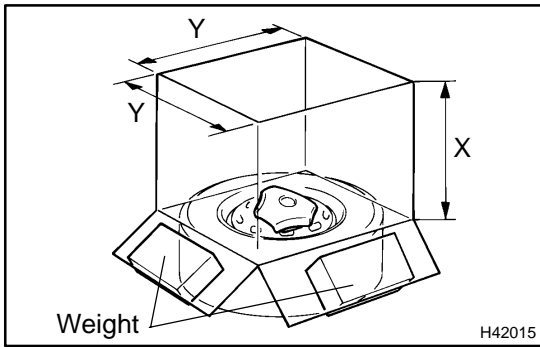

- (e) Cover the horn button assy with a cardboard box or tires.
 - Covering method using a cardboard box:
Cover the horn button assy with the cardboard box and weight the cardboard box down in 4 places with at least 190 N (20 kg, 44 lb).

Size of cardboard box:

Must exceed the following dimensions:

X = 460 mm (18.11 in.)

Y = 650 mm (25.59 in.)

NOTICE:

- When dimension Y of the cardboard box exceeds the diameter of the disc wheel with tire to which the horn button assy is tied, X should be the following size.
X = 460 mm (18.11 in.) + width of tire
- If a cardboard box smaller than the specified size is used, the cardboard box will be broken by the shock from the airbag deployment.

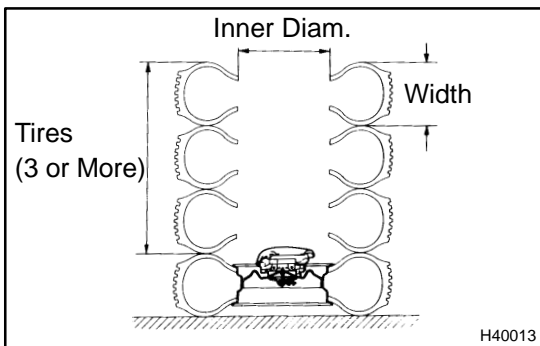

- Covering method using tires:
Place at least 3 tires without disc wheel on top of the disc wheel with tire to which the horn button assy is tied.

Tire size: Must exceed the following dimensions-

Width: 185 mm (7.28 in.)

Inner diameter: 360 mm (14.17 in.)

CAUTION:

Do not use tires with disc wheels.

NOTICE:

The tires may be marked by the airbag deployment, so use the redundant tires.

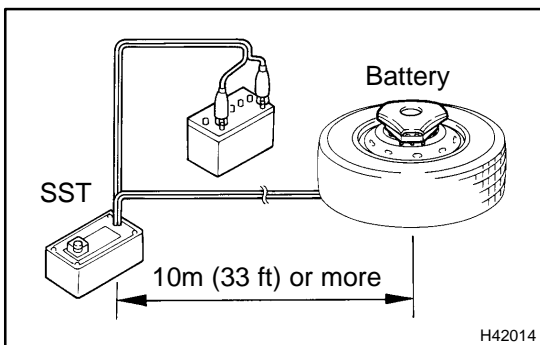

- (f) Deploy the airbag.
 - (1) Connect the SST red clip to the battery positive (+) terminal and the black clip to the battery negative (-) terminal.
 - (2) Check that no one is within 10 m (33 ft) area around the disc wheel which the horn button assy is tied to.
 - (3) Press the SST activation switch and deploy the airbag.

HINT:

The airbag deploys simultaneously as the LED of the SST activation switch lights up.



(g) Dispose the horn button assy (with airbag).

CAUTION:

- **The steering wheel pad is very hot when the airbag is deployed, so leave it alone for at least 30 minutes after deployment.**
 - **Use gloves and safety glasses when handling a horn button assy with the deployed airbag.**
 - **Always wash your hands with water after completing the operation.**
 - **Do not apply water, etc. to a horn button assy with the deployed airbag.**
- (1) Remove the horn button assy from the disc wheel.
 - (2) Place the horn button assy in a vinyl bag, tie the end tightly and dispose of it in the same way as other general parts disposal.