

MANUAL TRANSAXLE ASSY (MTM) COMPONENTS

4107W-01

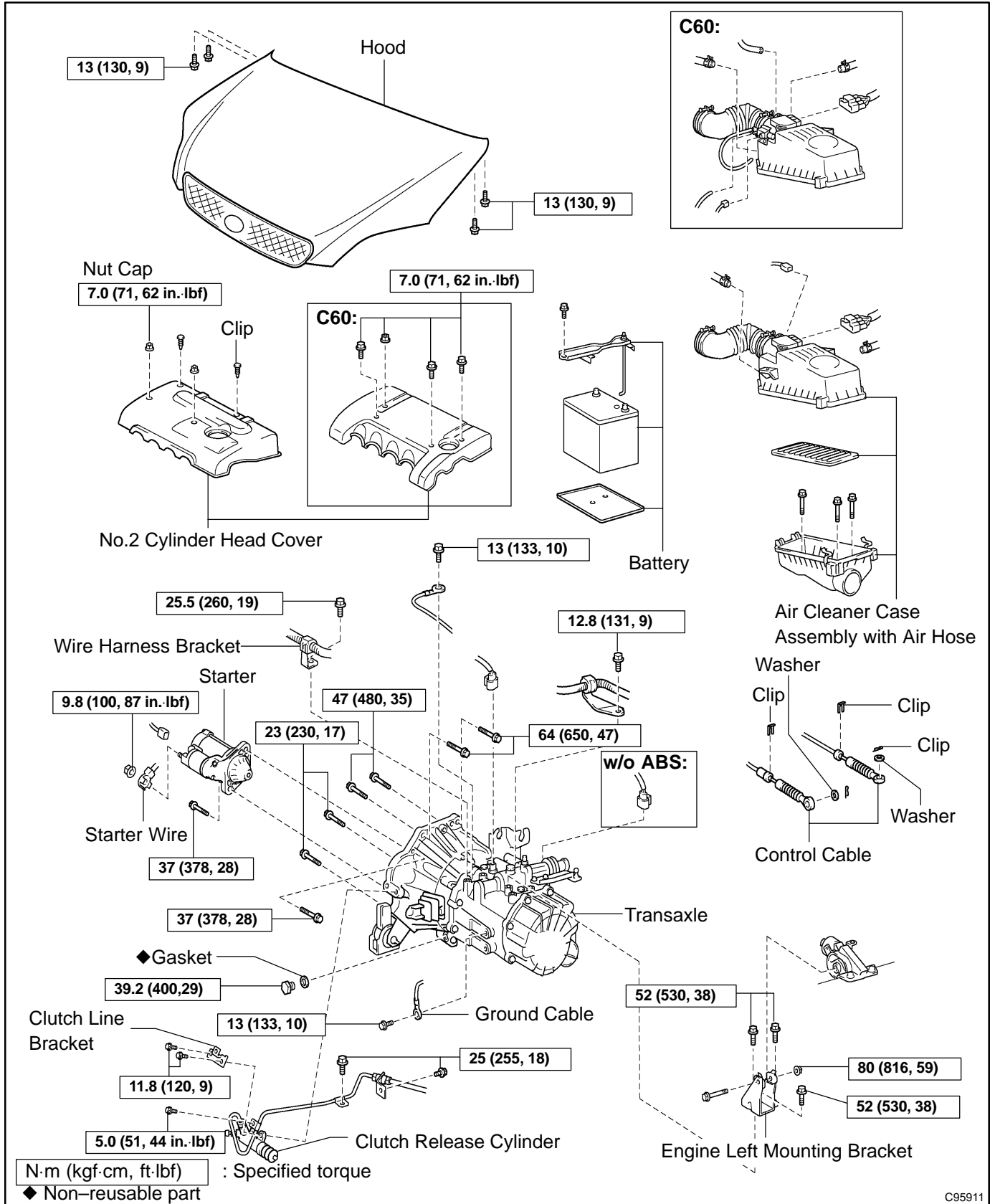

C95911

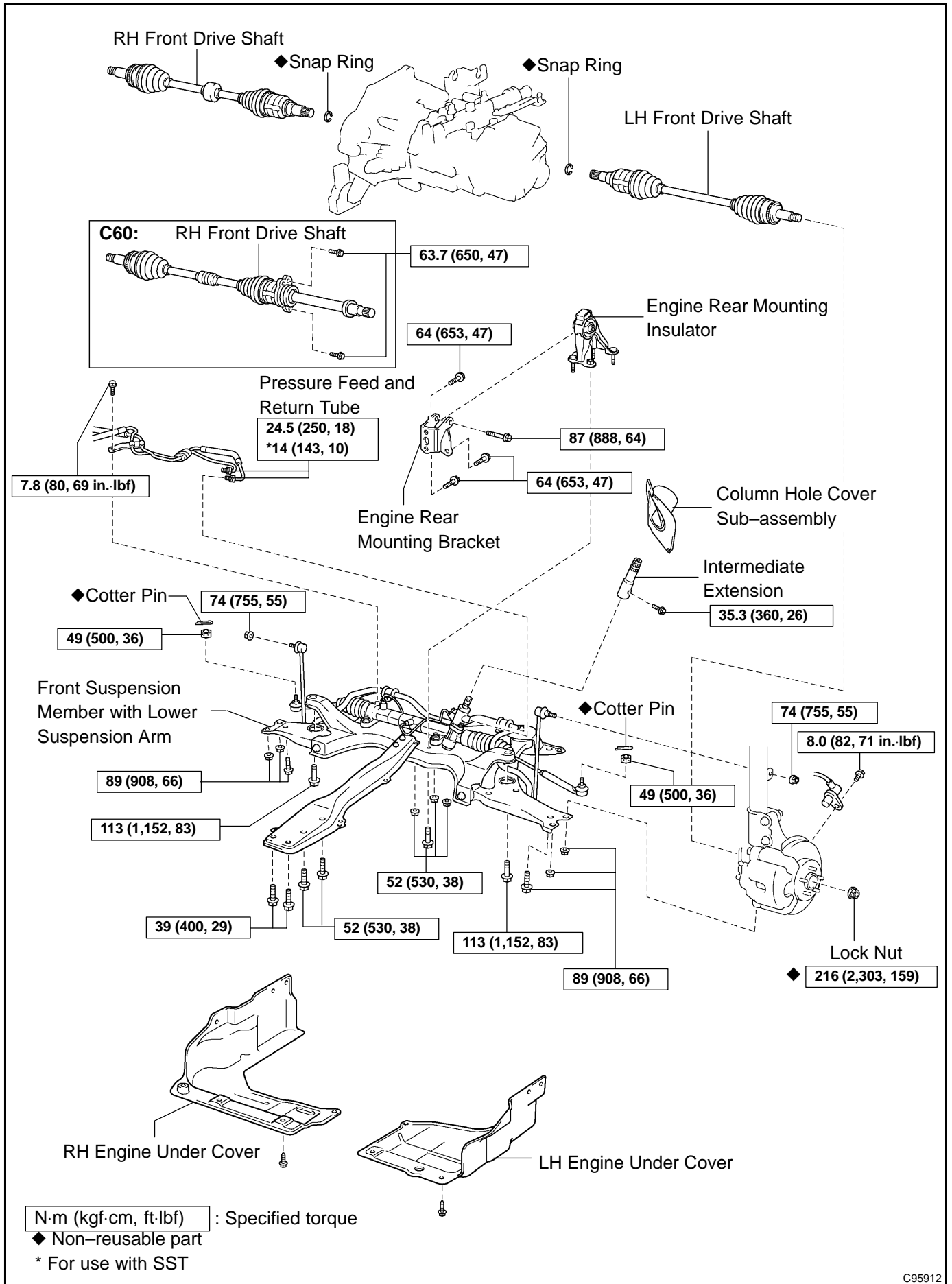

C95912