

# MANUAL TRANSAXLE ASSY (C59) COMPONENTS

4107Y-01

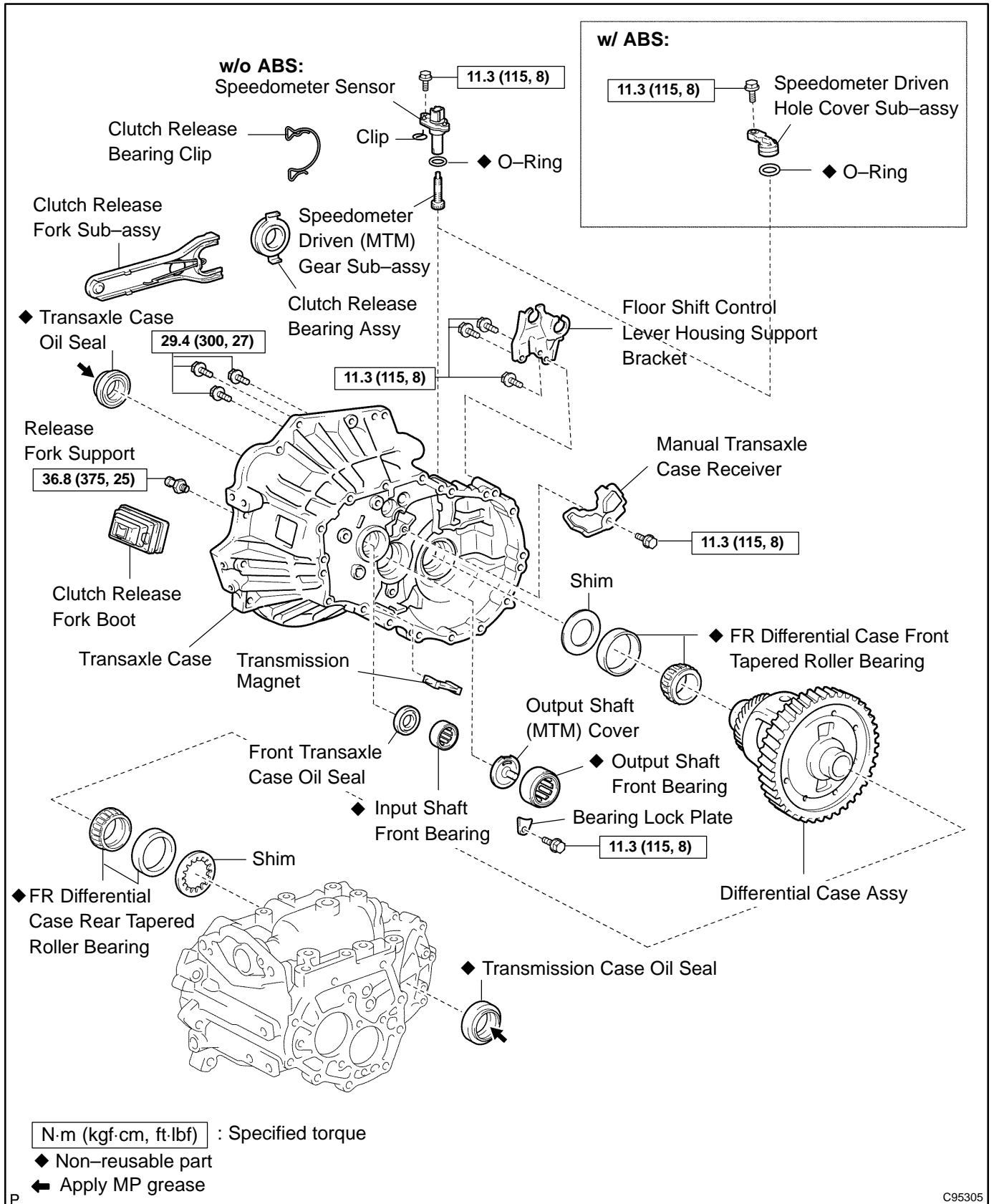

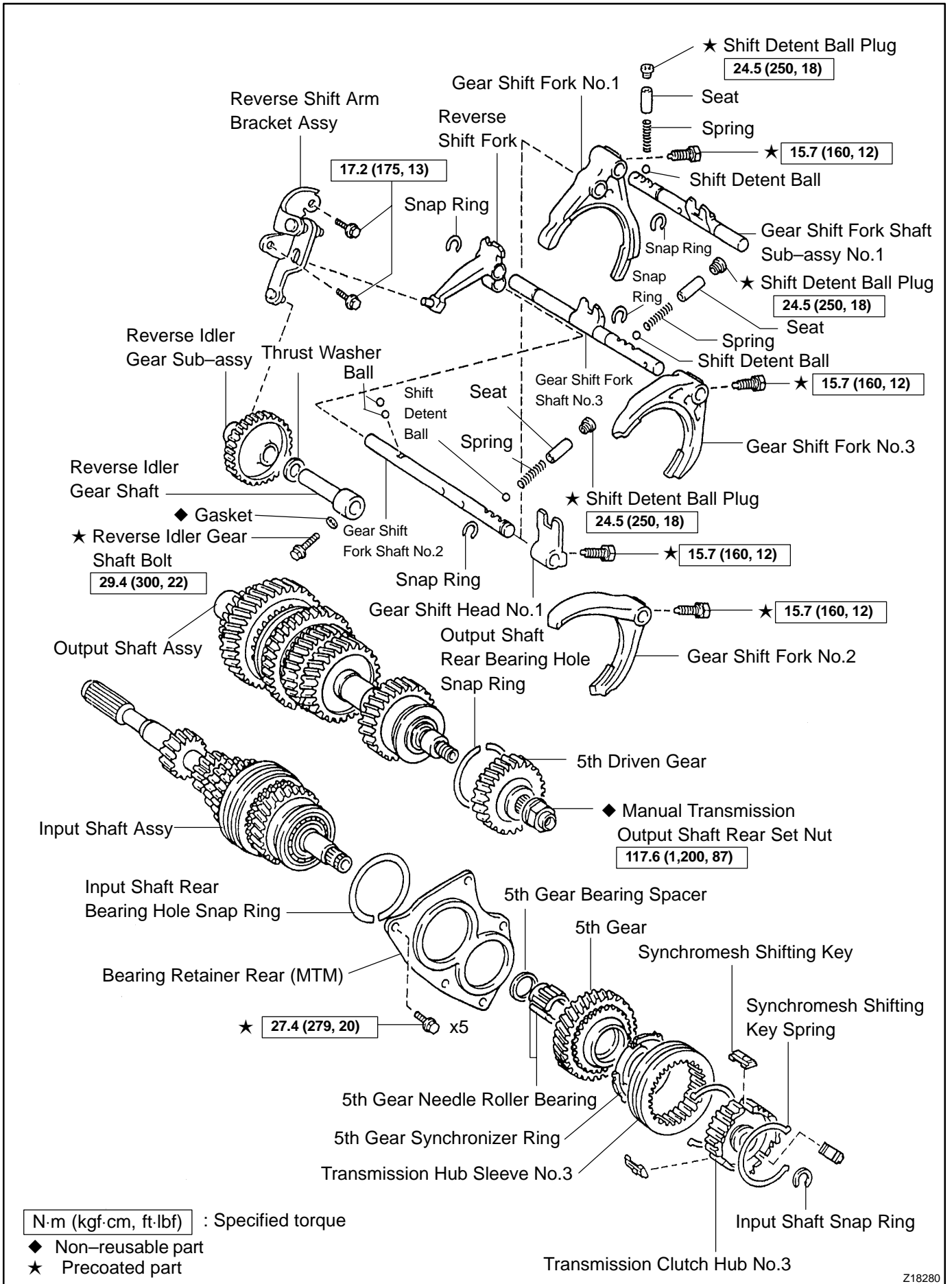

Z18280

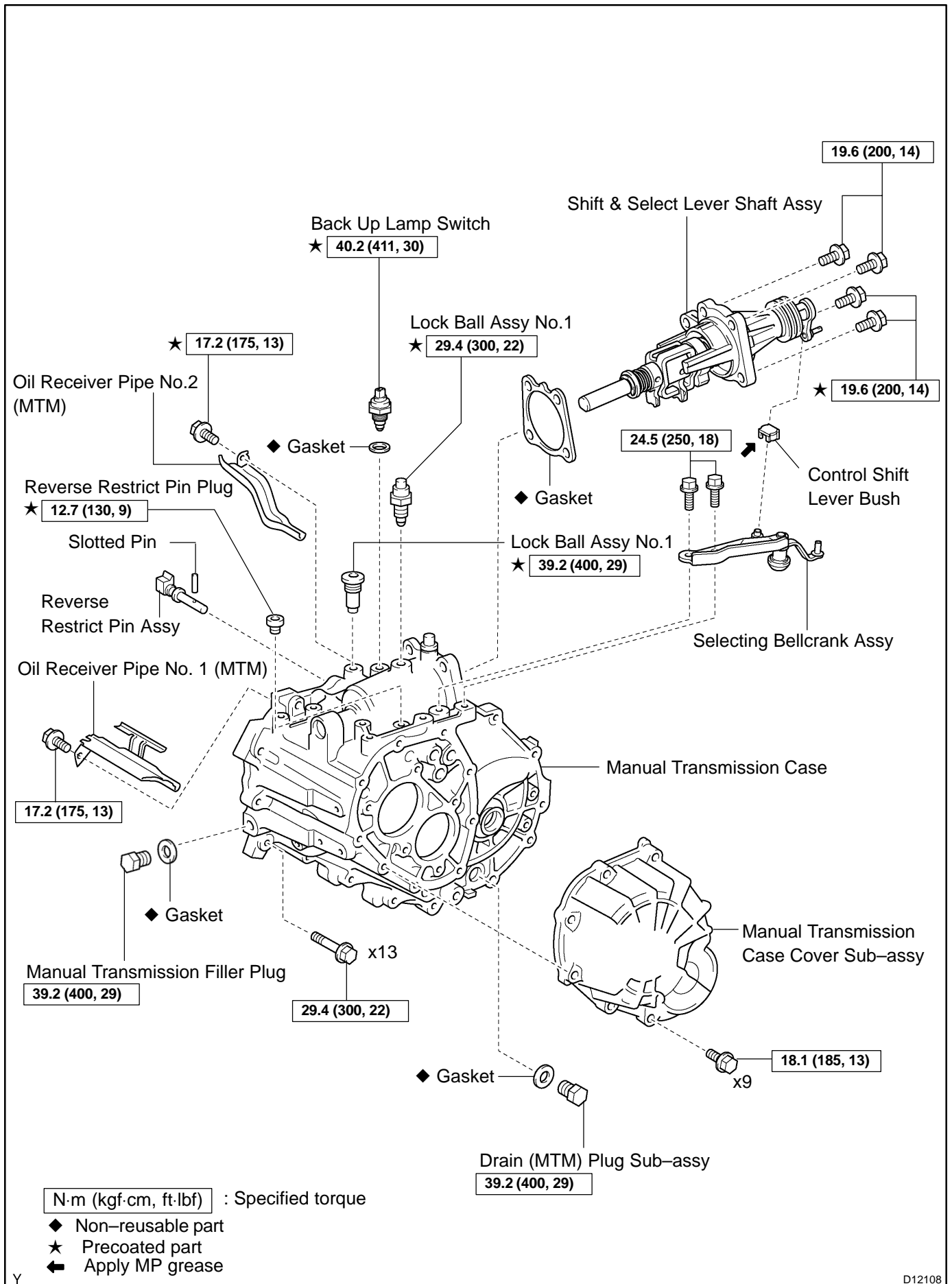

Y

D12108