

FLOOR SHIFT CABLE TRANSMISSION CONTROL SELECT (MTM)

4107V-01

REPLACEMENT

HINT:

COMPONENTS: See page 41-5 or 71-7

1. PRECAUTION

NOTICE:

Do not open the cover or the case of the ECU and various electrical devices unless absolutely necessary (If the IC terminals are touched, the IC may be destroyed by static electricity.).

2. DISCONNECT BATTERY NEGATIVE TERMINAL

3. REMOVE FLOOR SHIFT SHIFTER LEVER KNOB SUB-ASSY

4. REMOVE INSTRUMENT CLUSTER FINISH PANEL ASSY CTR (See page 71-10)

5. REMOVE INSTRUMENT PANEL BOX (See page 71-10)

6. REMOVE INSTRUMENT PANEL FINISH PANEL LOWER CENTER (See page 71-10)

7. REMOVE AIR BAG SENSOR ASSY CENTER (See page 60-39)

8. REMOVE FLOOR SHIFT CABLE TRANSMISSION CONTROL SELECT

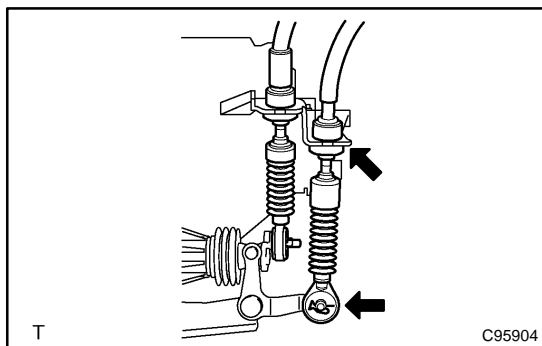

(a) Remove the clip, washer and disconnect the cable end of the select cable from the transaxle.

(b) Remove the clip and disconnect the select cable from the bracket.

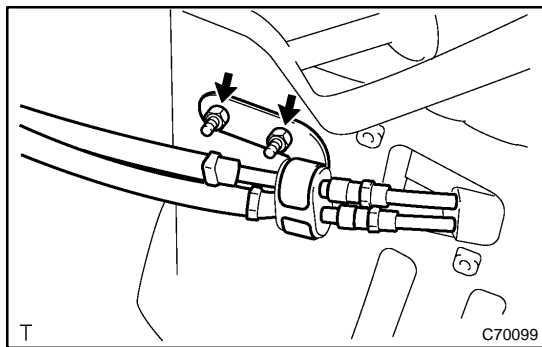

(c) Remove the 2 nuts and disconnect the select cable.

(d) Disconnect the select cable from the clamp.

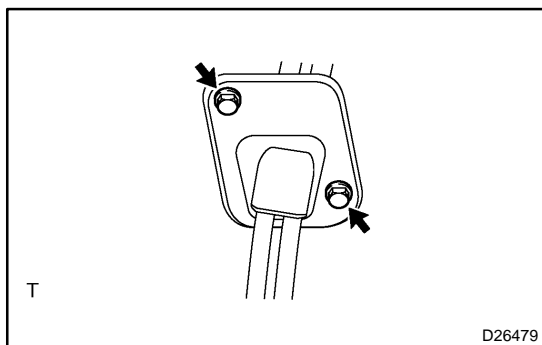

(e) Remove the 2 bolts and shift cable grommet retainer.

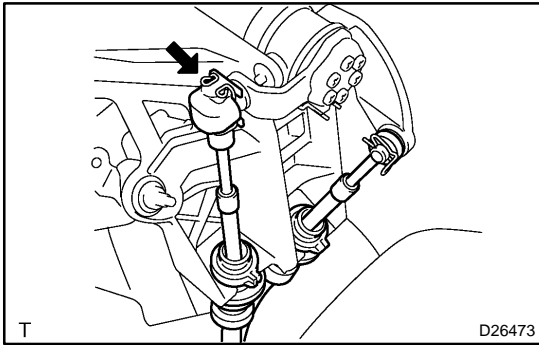

- (f) Remove the clip and disconnect the cable end of the select cable from the shift lever assy.

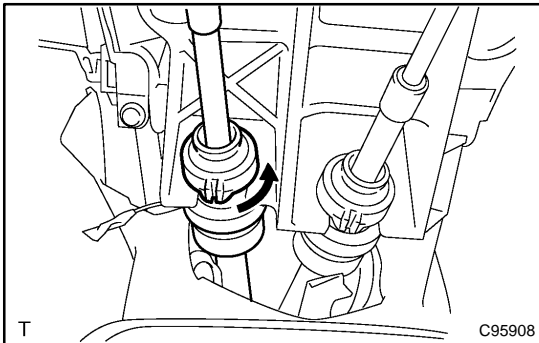

- (g) Turn the lock and disconnect the select cable from the shift lever assy.
 (h) Pull out the select cable from the floor.

9. INSTALL FLOOR SHIFT CABLE TRANSMISSION CONTROL SELECT

- (a) Pull in the select cable to the floor.

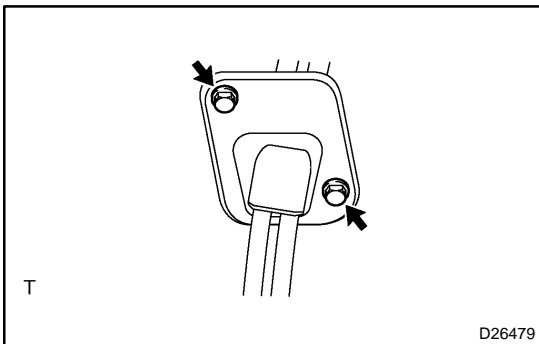

- (b) Install the shift cable grommet retainer with the 2 bolts.
Torque: 5.0 N·m (51 kgf·cm, 44 in·lbf)

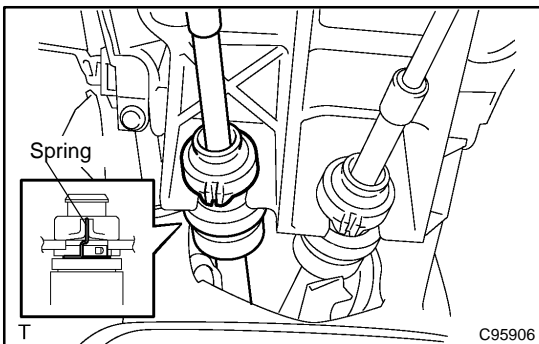

- (c) Connect the select cable to the shift lever assy.

NOTICE:

- The projecting part of the cable outer should face upward when the shift cable is installed.
- Make sure that after installation the cable outer spring is moved to the place shown in the illustration.

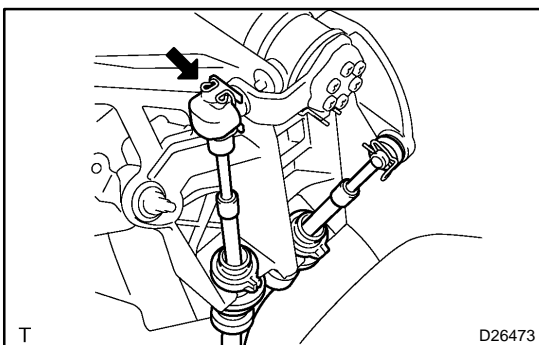

- (d) Connect the select cable end with the clip to the shift lever assy.
 (e) Connect the select cable to the clamp.

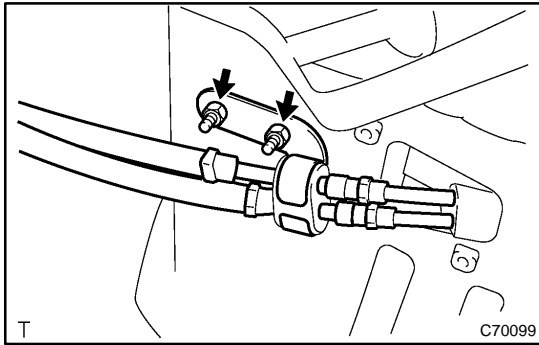

- (f) Connect the select cable with the 2 nuts.
Torque: 5.0 N·m (51 kgf·cm, 44 in.-lbf)

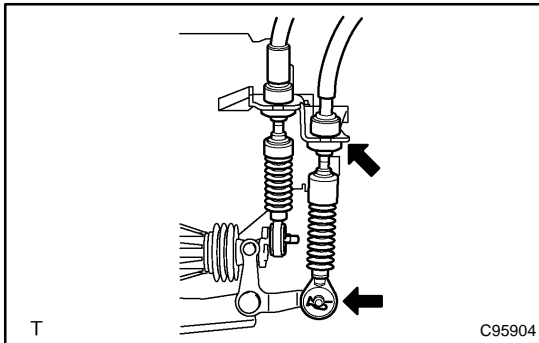

- (g) Connect the select cable with the clip from the bracket.
(h) Connect the cable end of the select cable and with the washer and clip to the transaxle.

10. INSTALL AIR BAG SENSOR ASSY CENTER (See page 60-39)

SST 09249-63010

11. INSPECT SRS WARNING LIGHT (See page 05-543)