

TRANSMISSION WIRE (U240E)

400N4-01

REPLACEMENT

1. REMOVE ENGINE UNDER COVER LH
2. DRAIN AUTOMATIC TRANSAXLE FLUID
 - (a) Remove the drain plug and gasket, and drain ATF.
 - (b) Install a new gasket and drain plug.
Torque: 49 N·m (500 kgf·cm, 36 ft·lbf)

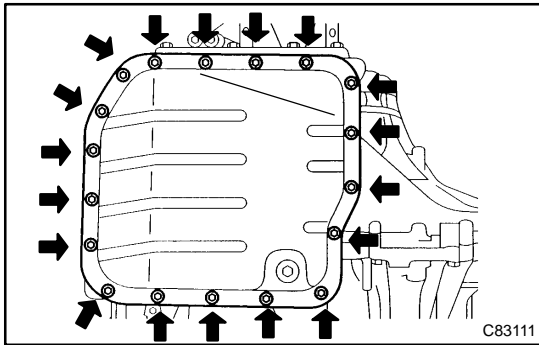

3. REMOVE AUTOMATIC TRANSAXLE OIL PAN SUB-ASSY

- (a) Remove the 18 bolts, oil pan and gasket.

NOTICE:

Some fluid will remain in the oil pan. Remove all pan bolts, and carefully remove the oil pan assembly.

- (b) Remove the 2 magnets from the oil pan.

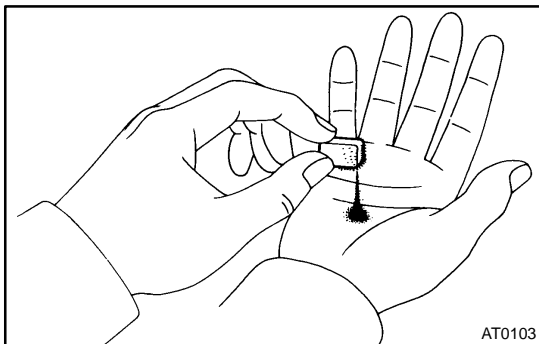

- (c) Examine particles in pan.

- (1) Remove the magnets and use them to collect any steel chips. Look carefully at the chips and particles in the pan and the magnet to anticipate what type of wear you will find in the transaxle.
Steel (magnetic): bearing, gear and plate wear
Brass (non-magnetic): bearing wear

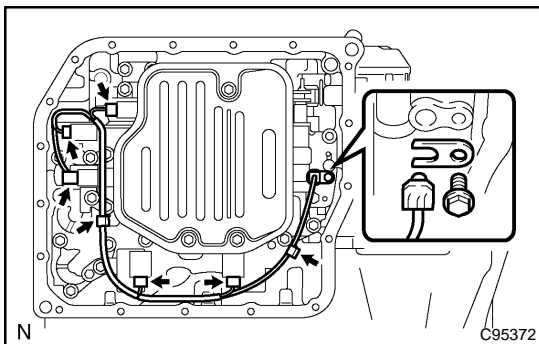

4. DISCONNECT TRANSMISSION WIRE

- (a) Disconnect the 5 shift solenoid valve connectors.
- (b) Remove the bolt and lock plate, and disconnect the ATF temperature sensor.

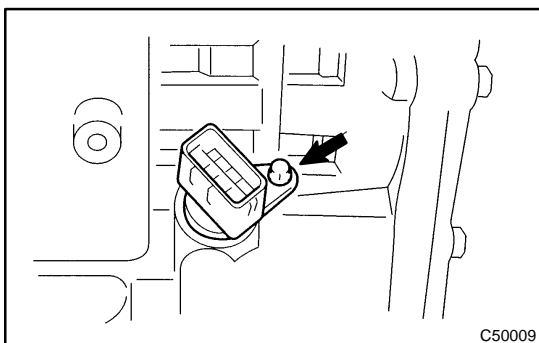

5. REMOVE TRANSMISSION WIRE

- (a) Disconnect the transmission wire connector.
- (b) Remove the bolt and transmission wire.

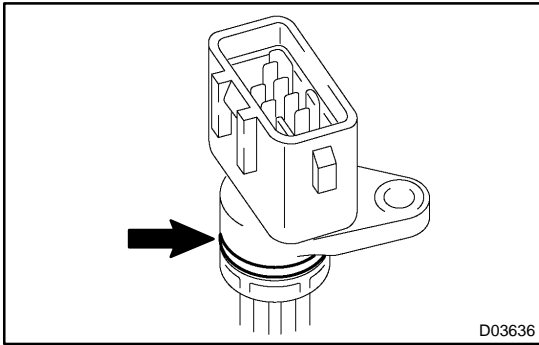

6. INSTALL TRANSMISSION WIRE

- (a) Coat a O-ring of the transmission wire connector with ATF.
- (b) Install the transmission wire.

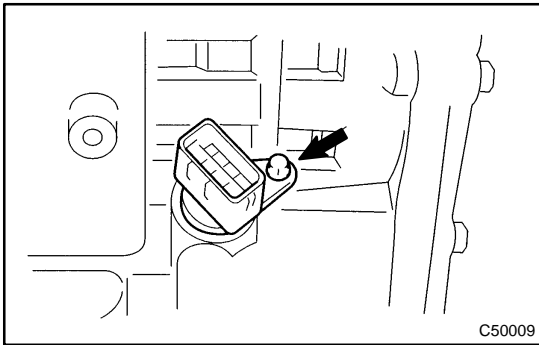

- (c) Install the bolt.
Torque: 5.4 N·m (55 kgf·cm, 48 in.-lbf)

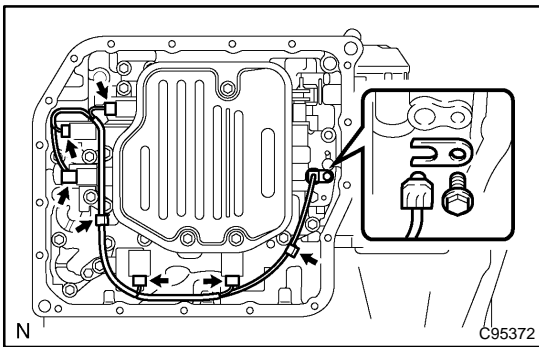

7. CONNECT TRANSMISSION WIRE

- (a) Coat a O-ring of the ATF temperature sensor with ATF.
- (b) Install the ATF temperature sensor with the lock plate and bolt.
Torque: 6.6 N·m (67 kgf·cm, 58 in.-lbf)
- (c) Connect the 5 shift solenoid valve connectors.

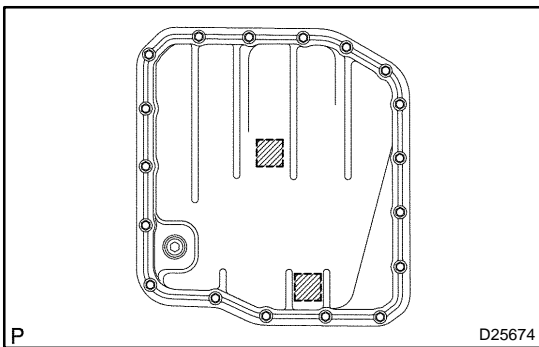

8. INSTALL AUTOMATIC TRANSAXLE OIL PAN SUB-ASSY

- (a) Install the 2 magnets in the oil pan.
- (b) Apply seal packing or equivalent to 18 bolts.

**Seal packing:
THREE BOND 2430 or equivalent**

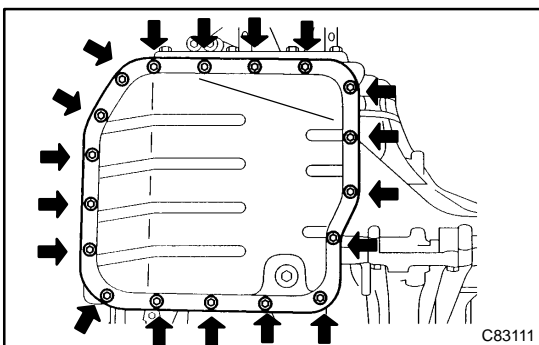

- (c) Install a new gasket, oil pan and 18 bolts to the transaxle case.
Torque: 7.8 N·m (80 kgf·cm, 69 in.-lbf)

NOTICE:

Because the bolts should be seal bolts, apply seal packing to bolts and tighten them within 10 minutes after application.

9. INSTALL ENGINE UNDER COVER LH
10. ADD AUTOMATIC TRANSAXLE FLUID
11. INSPECT AUTOMATIC TRANSAXLE FLUID (See page [40-2](#))