

OVERHAUL

HINT:

Overhaul the RH side by the same procedures as LH side.

1. REMOVE REAR WHEEL
2. DRAIN BRAKE FLUID

NOTICE:

Wash the brake fluid off immediately if it comes into contact with any painted surface.

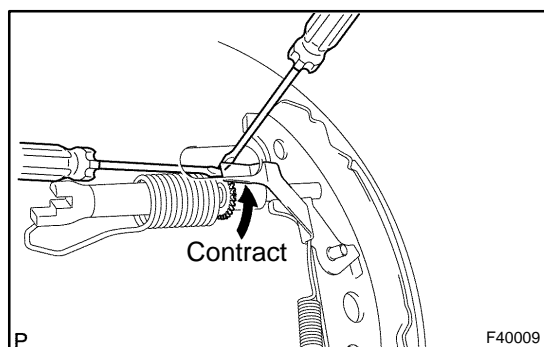

3. REMOVE REAR BRAKE DRUM SUB-ASSY

- (a) Release the parking brake lever, and remove the brake drum.

HINT:

If the brake drum cannot be removed easily, do the following steps.

- (b) Remove the hole plug and insert a screwdriver through the hole in the backing plate, and hold the automatic adjusting lever away from the adjuster.
- (c) Using an another screwdriver, reduce the brake shoe adjuster by turning the adjusting wheel.

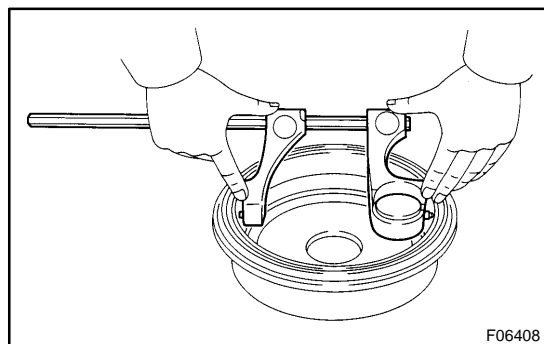

4. INSPECT BRAKE DRUM INSIDE DIAMETER

- (a) Using a brake drum gauge or equivalent, measure the inside diameter of the drum.

Standard inside diameter: 228.6 mm (9.000 in.)

Maximum inside diameter: 229.6 mm (9.039 in.)

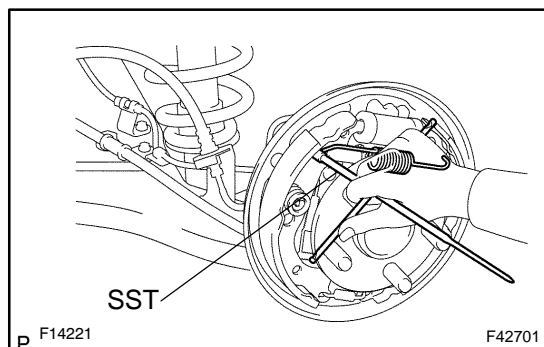

5. REMOVE FRONT BRAKE SHOE

- (a) Using SST, disconnect the return spring from the front brake shoe.

SST 09703-30010

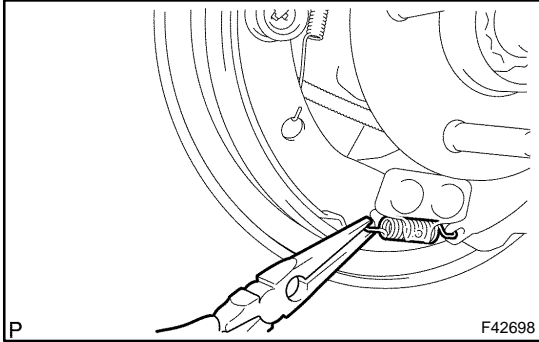

- (b) Using a needle-nose pliers, remove the anchor spring.

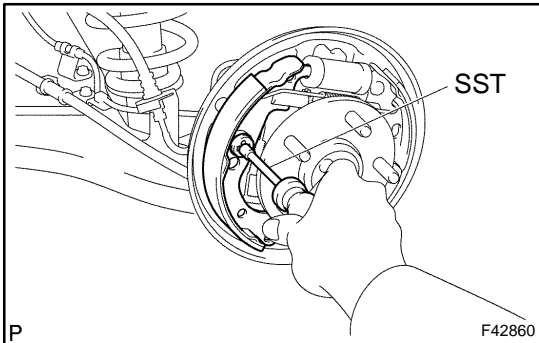

- (c) Using SST, remove the 2 cups, shoe hold-down spring and pin, and remove the front brake shoe.
SST 09718-00010

6. REMOVE PARKING BRAKE SHOE STRUT SET LH

- (a) Remove the parking brake shoe strut set LH with return spring from the rear brake shoe.

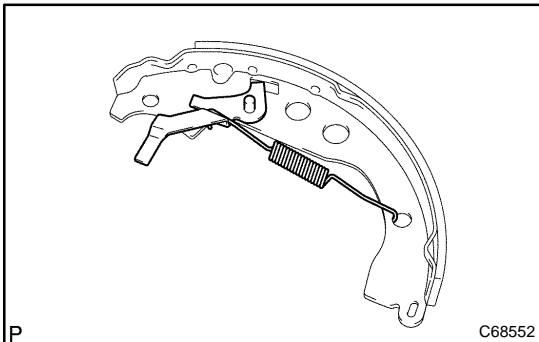

7. REMOVE REAR BRAKE AUTOMATIC ADJUST LEVER LH

- (a) Remove the automatic adjust lever torsion spring and automatic adjust lever.

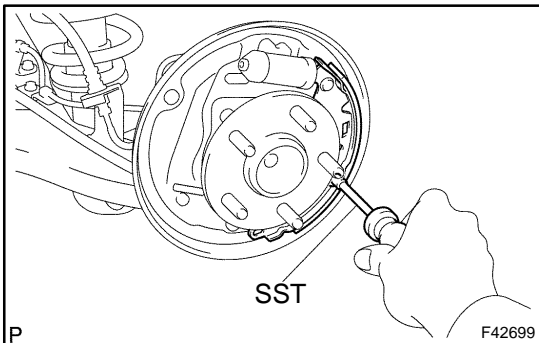

8. REMOVE REAR BRAKE SHOE

- (a) Using SST, remove the 2 cups, shoe hold-down spring and pin.
SST 09718-00010

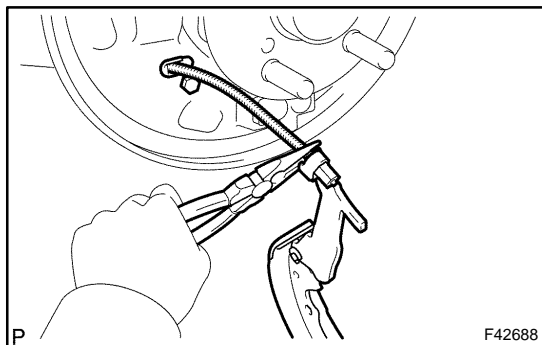

- (b) Using a needle-nose pliers, disconnect the parking brake cable No.3 and remove the rear brake shoe.
- (c) Remove the anchor spring from rear brake shoe.

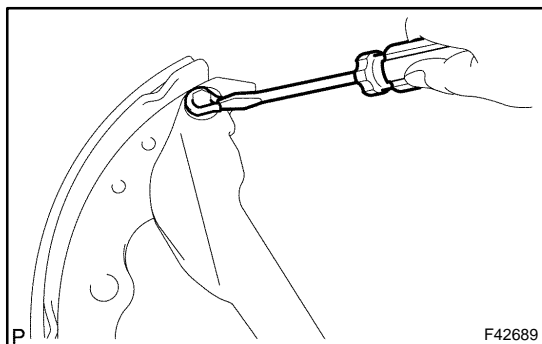

9. REMOVE REAR BRAKE PARKING BRAKE SHOE LEVER SUB-ASSY

- (a) Using a screwdriver, remove the C-washer and parking brake shoe lever.

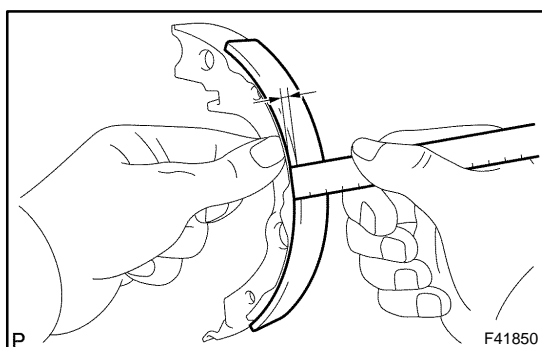

10. INSPECT REAR DRUM BRAKE SHOE LINING THICKNESS

- (a) Using a ruler, measure the thickness of the shoe lining.
Standard thickness: 5.5 mm (0.217 in.)
Minimum thickness: 1.0 mm (0.039 in.)

If the lining thickness is at the minimum thickness or less, or if there is severe, uneven wear, replace the brake shoe.

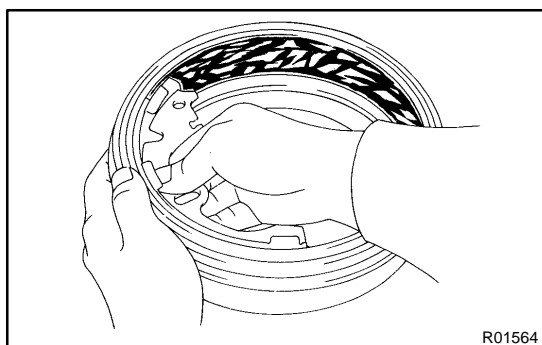

11. INSPECT BRAKE DRUM AND REAR DRUM BRAKE SHOE LINING FOR PROPER CONTACT

- (a) Apply chalk to the inside surface of the drum, then grind drum on the brake shoe lining to fit.

If the contact between the drum and the shoe lining is improper, repair it using a brake shoe grinder or replace the brake shoe assembly.

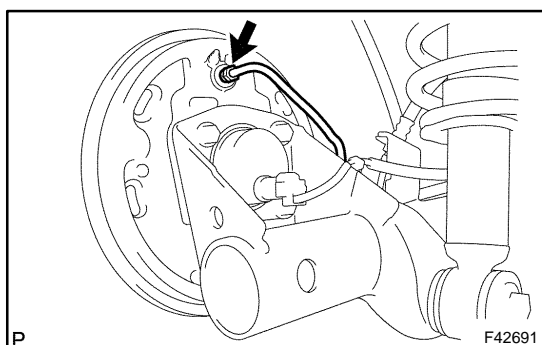

12. REMOVE LH, FRONT OR UPPER REAR WHEEL BRAKE CYLINDER ASSY

- (a) Using SST, disconnect the brake tube, use a container to catch brake fluid.
 SST 09023-00100
- (b) Remove the 2 bolts and wheel cylinder.

13. REMOVE REAR WHEEL CYLINDER CUP KIT

- (a) Remove the 2 cylinder boots from the wheel cylinder.
- (b) Remove the 2 pistons and compression spring.
- (c) Remove the 2 cups from each piston.
- (d) Remove the bleeder plug cap and bleeder plug from the wheel cylinder.

14. INSPECT BRAKE WHEEL CYLINDER

- (a) Check the cylinder bore and piston for rust or scoring.

15. INSTALL REAR WHEEL CYLINDER CUP KIT

- (a) Temporarily tighten the bleeder plug to the wheel cylinder, and install the bleeder plug cap.

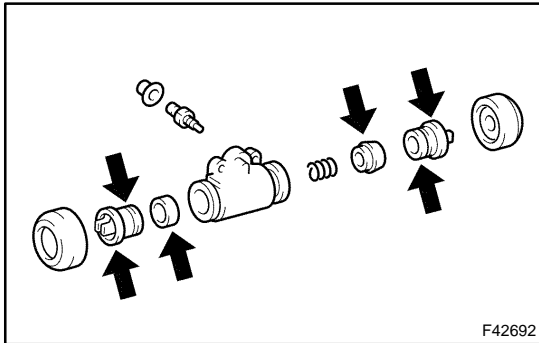

- (b) Apply the lithium soap base glycol grease to the 2 new wheel cylinder cups and the 2 pistons.
- (c) Install the 2 wheel cylinder cups to each piston.
- (d) Install the compression spring and 2 pistons to the wheel cylinder.
- (e) Install the 2 new cylinder dust boots to the wheel cylinder.

16. INSTALL LH, FRONT OR UPPER REAR WHEEL BRAKE CYLINDER ASSY

- (a) Install the wheel cylinder with the bolt.
Torque: 10 N·m (102 kgf·cm, 7 ft·lbf)
- (b) Using SST, connect the brake tube.
SST 09023-00100
Torque: 15.2 N·m (155 kgf·cm, 11 ft·lbf)

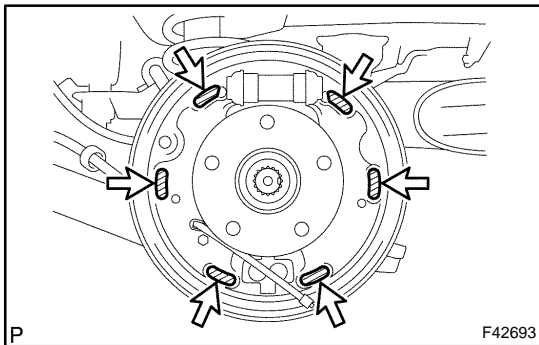
**17. APPLICATION HIGH TEMPERATURE GREASE**

- (a) Apply the high temperature grease to the shoe attached surface of backing plate.

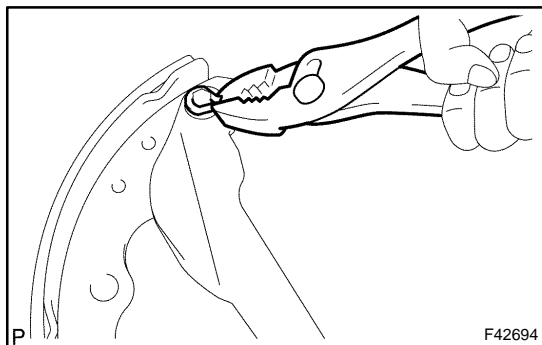

18. INSTALL REAR BRAKE PARKING BRAKE SHOE LEVER SUB-ASSY

- (a) Using a pliers, install the parking brake shoe lever with a new C-washer.

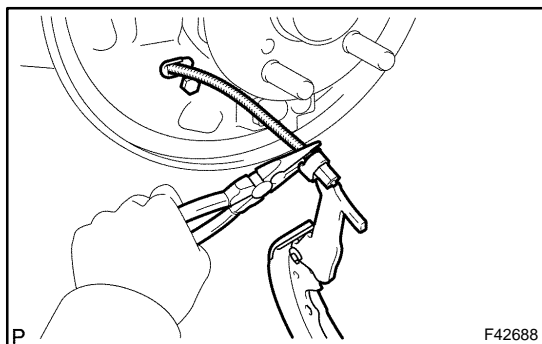

19. INSTALL REAR BRAKE SHOE

- (a) Using a needle-nose pliers, connect the parking brake cable No.3 to the parking brake shoe lever.

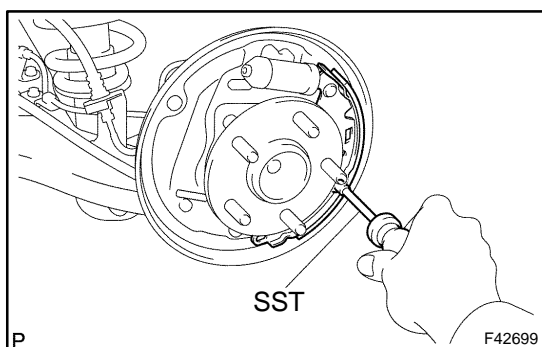

- (b) Using SST, install the rear brake shoe, pin, shoe hold-down spring and 2 cups.
SST 09718-00010

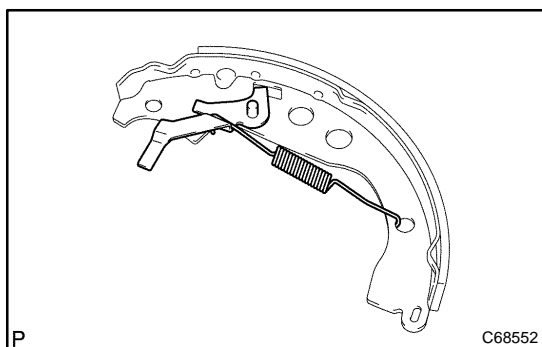

20. INSTALL REAR BRAKE AUTOMATIC ADJUST LEVER LH

- (a) Install the automatic adjust lever and automatic adjust lever spring to the front brake shoe.

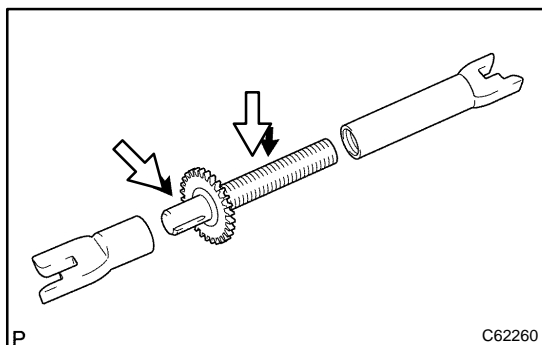

21. INSTALL PARKING BRAKE SHOE STRUT SET LH

- (a) Apply the high temperature grease to the adjusting bolt.
(b) Install the parking brake shoe strut set LH with return spring.

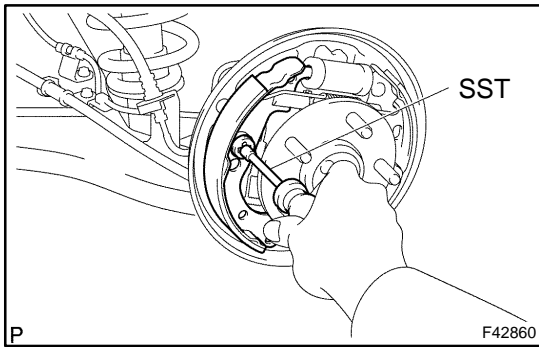
**22. INSTALL FRONT BRAKE SHOE**

- (a) Using SST, install the front brake shoe, pin, shoe hold-down spring and 2 cups.
SST 09718-00010

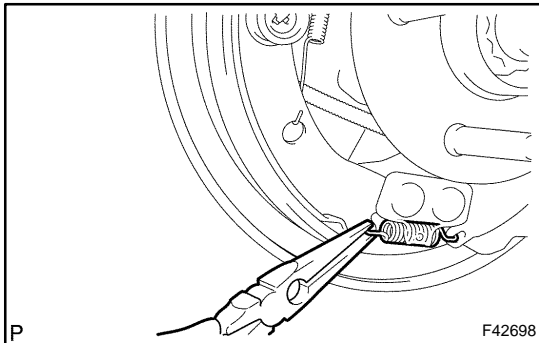

- (b) Using a needle-nose pliers, install the anchor spring to each brake shoe.

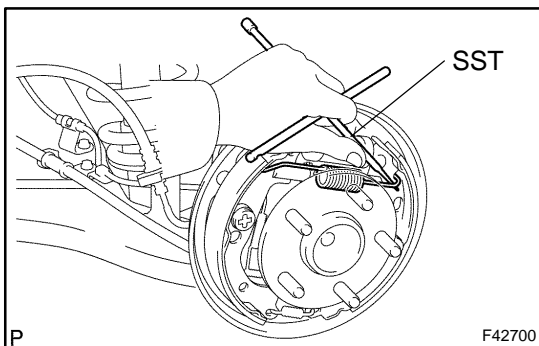

- (c) Using SST, connect the return spring to each shoe.
SST 09703-30010

23. CHECK REAR DRUM BRAKE INSTALLATION

- (a) Check that each part is installed properly.

NOTICE:

There should be no oil or grease adhering to the friction surfaces of the shoe lining and drum.

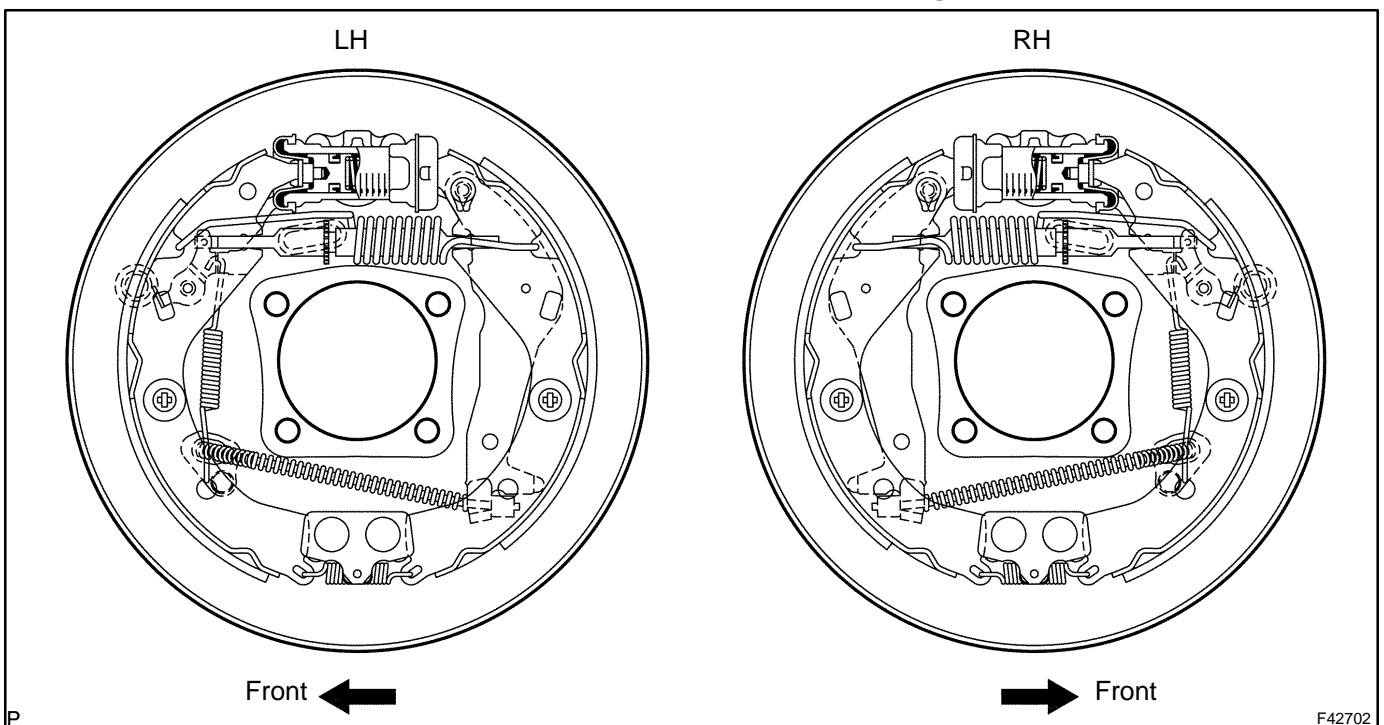

24. INSTALL REAR BRAKE DRUM SUB-ASSY**25. ADJUST REAR DRUM BRAKE SHOE CLEARANCE**

(a) Temporarily install the hub nuts.

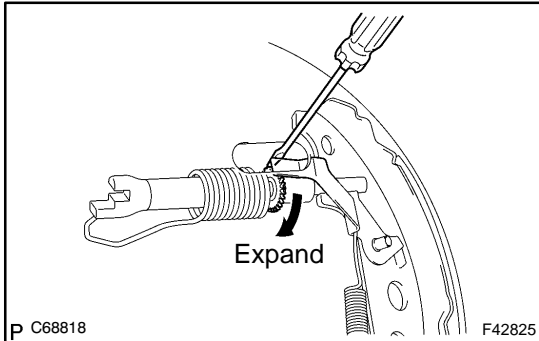

(b) Remove the hole plug, and turn the adjuster and expand the shoe until the drum locks.

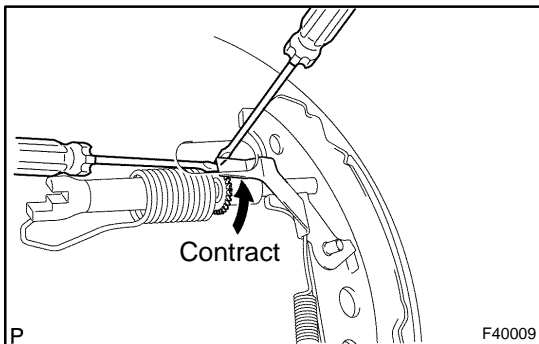

(c) Using a screwdriver, back off the adjuster 8 notches.

(d) Install the hole plug.

26. FILL RESERVOIR WITH BRAKE FLUID**27. BLEED MASTER CYLINDER (See page 32-6)**

SST 09023-00100

28. BLEED BRAKE LINE (See page 32-6)**29. CHECK FLUID LEVEL IN RESERVOIR****30. CHECK BRAKE FLUID LEAKAGE****31. INSTALL REAR WHEEL**

Torque: 103 N·m (1,050 kgf·cm, 76 ft·lbf)

32. INSPECT PARKING BRAKE LEVER TRAVEL (See page 33-2)**33. ADJUST PARKING BRAKE LEVER TRAVEL (See page 33-2)**