

# OIL FILTER SUB-ASSY (2ZZ-GE)

## REPLACEMENT

1707V-01

### CAUTION:

- Prolonged and repeated contact with mineral oil will result in the removal of natural fats from the skin, leading to dryness, irritation and dermatitis. In addition, used engine oil contains potentially harmful contaminants which may cause skin cancer.
  - Exercise caution in order to minimize the length and frequency of contact of your skin to used oil. Wear protective clothing and gloves. Wash your skin thoroughly with soap and water, or use water-less hand cleaner to remove any used engine oil. Do not use gasoline, thinners, or solvents.
  - In order to preserve the environment, used oil and used oil filter must be disposed of only at designated disposal sites.
1. REMOVE ENGINE UNDER COVER RH
  2. DRAIN ENGINE OIL
    - (a) Remove the oil pan drain plug and drain the engine oil.

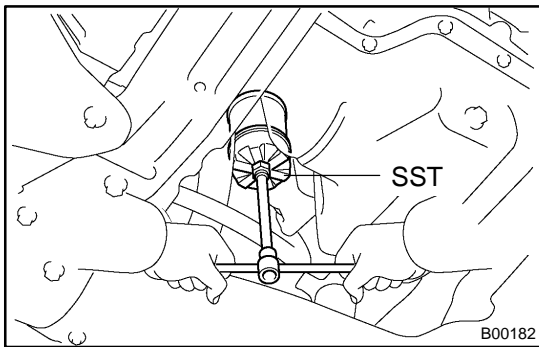

### 3. REMOVE OIL FILTER SUB-ASSY

- (a) Using SST, remove the oil filter  
SST 09228-06501

### 4. INSTALL OIL FILTER SUB-ASSY

- (a) Check and clean the oil filter installation surface.
- (b) Apply clean engine oil to the gasket of a new oil filter.
- (c) Lightly screw the oil filter into place, and tighten it until the gasket contacts the seat.
- (d) Using SST, tighten it an additional 3/4 turn.  
SST 09228-06501

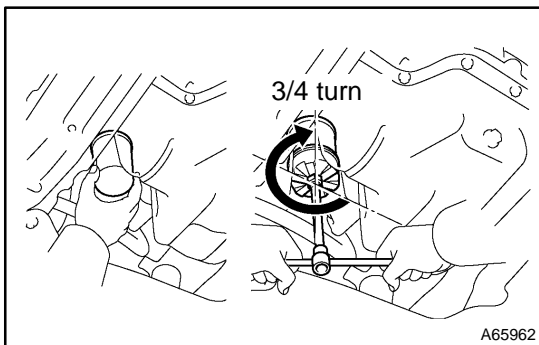

### 5. INSTALL OIL PAN DRAIN PLUG

- (a) Clean and install the oil pan drain plug with a new gasket.  
**Torque: 37 N·m (377 kgf·cm, 27 ft·lbf)**

**6. ADD ENGINE OIL****Capacity:****Drain and refill w/ Oil filter change 4.4 liters (4.7 US qts, 3.9 Imp. qts)****Drain and refill w/o Oil filter change 4.2 liters (4.4 US qts, 3.7 Imp. qts)****Dry fill 4.8 liters (5.1 US qts, 4.2 Imp. qts)****7. INSPECT OIL LEAK**