

PARTIAL ENGINE ASSY (2ZZ-GE) COMPONENTS

140R7-01

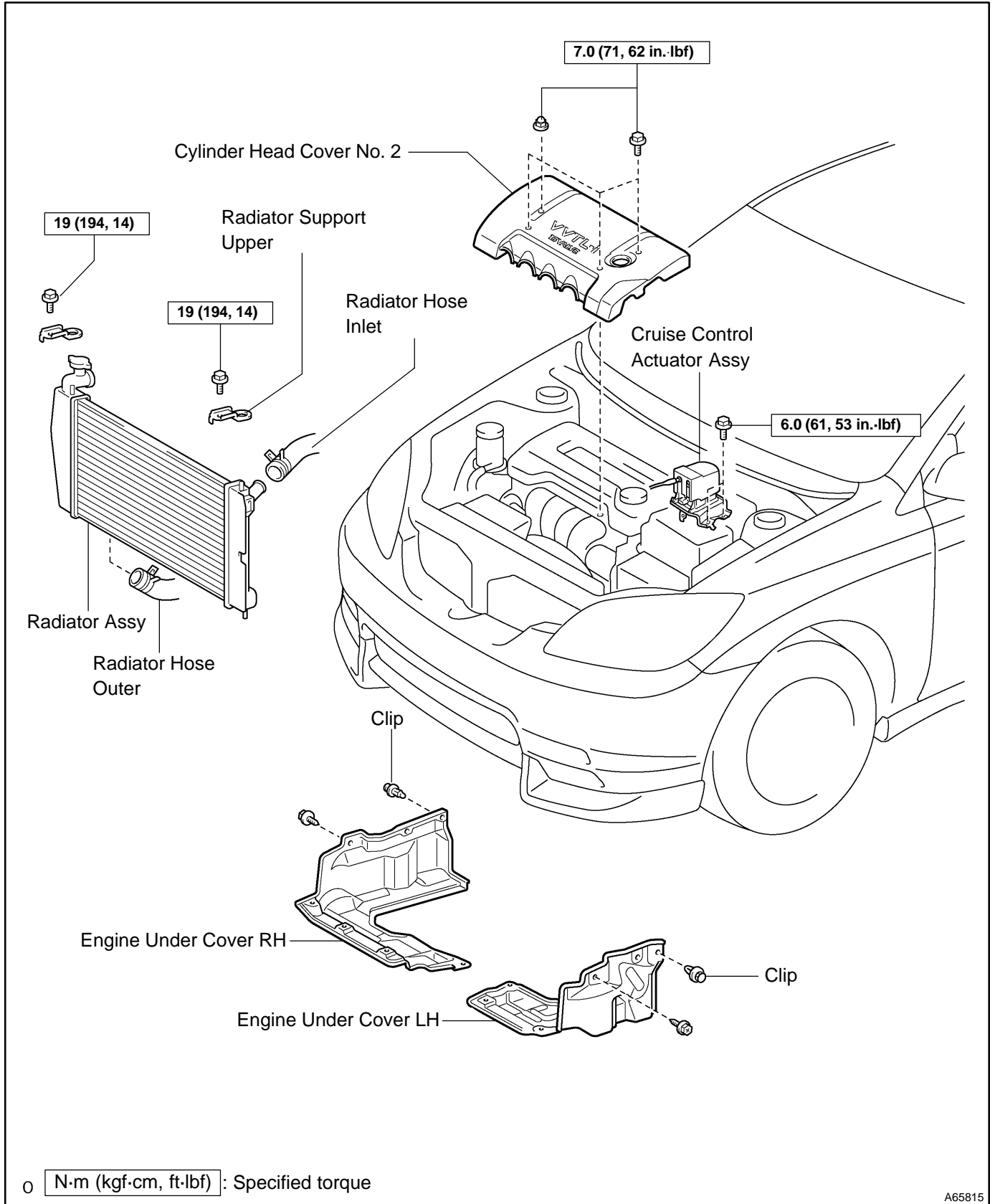

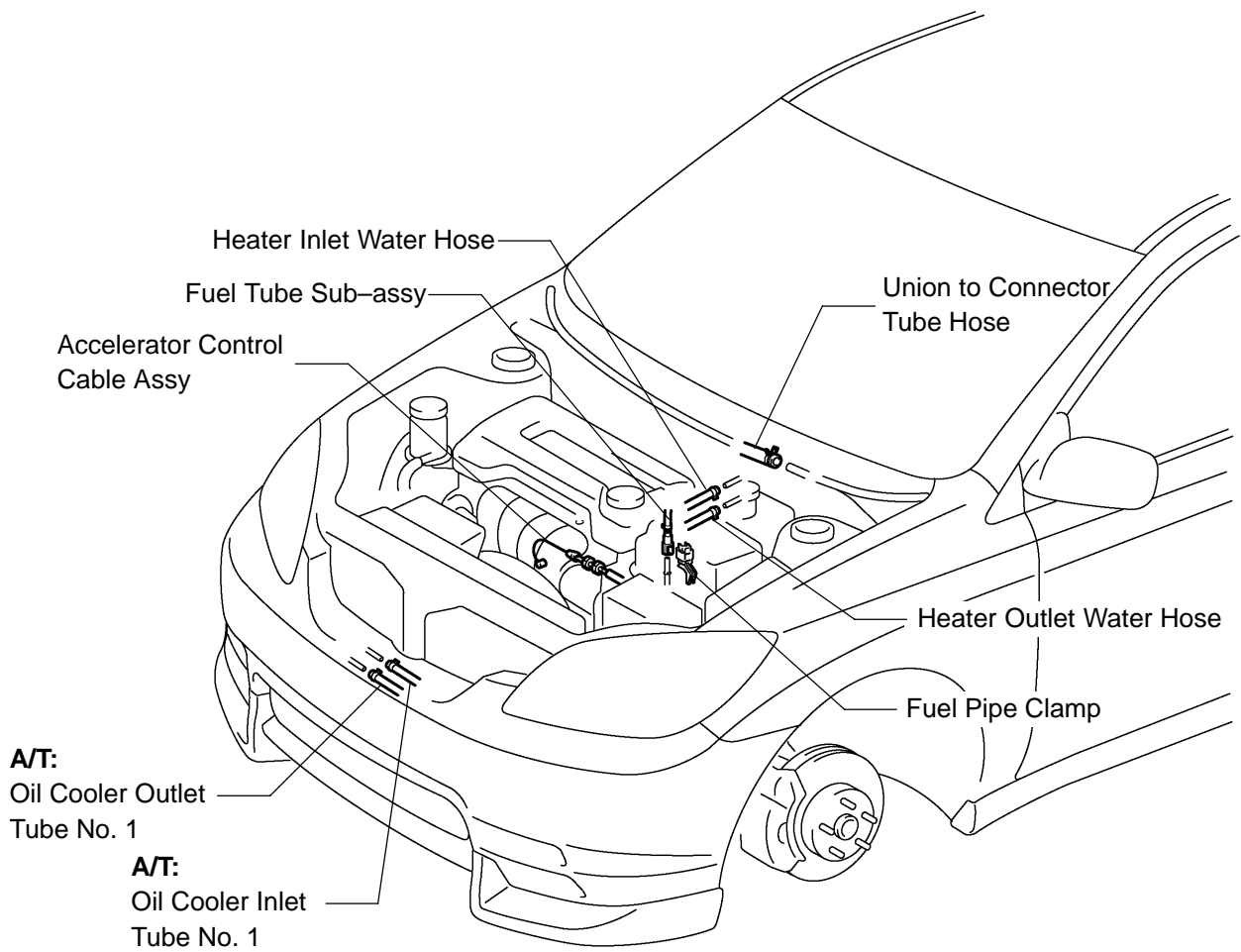

5.0 (51, 44 in. lbf)

Battery Clamp Sub-assy

Battery

Battery Tray

Battery Carrier

7.0 (71, 62 in. lbf)

Air Cleaner Cap Sub-assy

Air Cleaner Filter Element Sub-assy

Air Cleaner Case Sub-assy

13 (132, 10)

N·m (kgf·cm, ft·lbf) : Specified torque

0

A65816

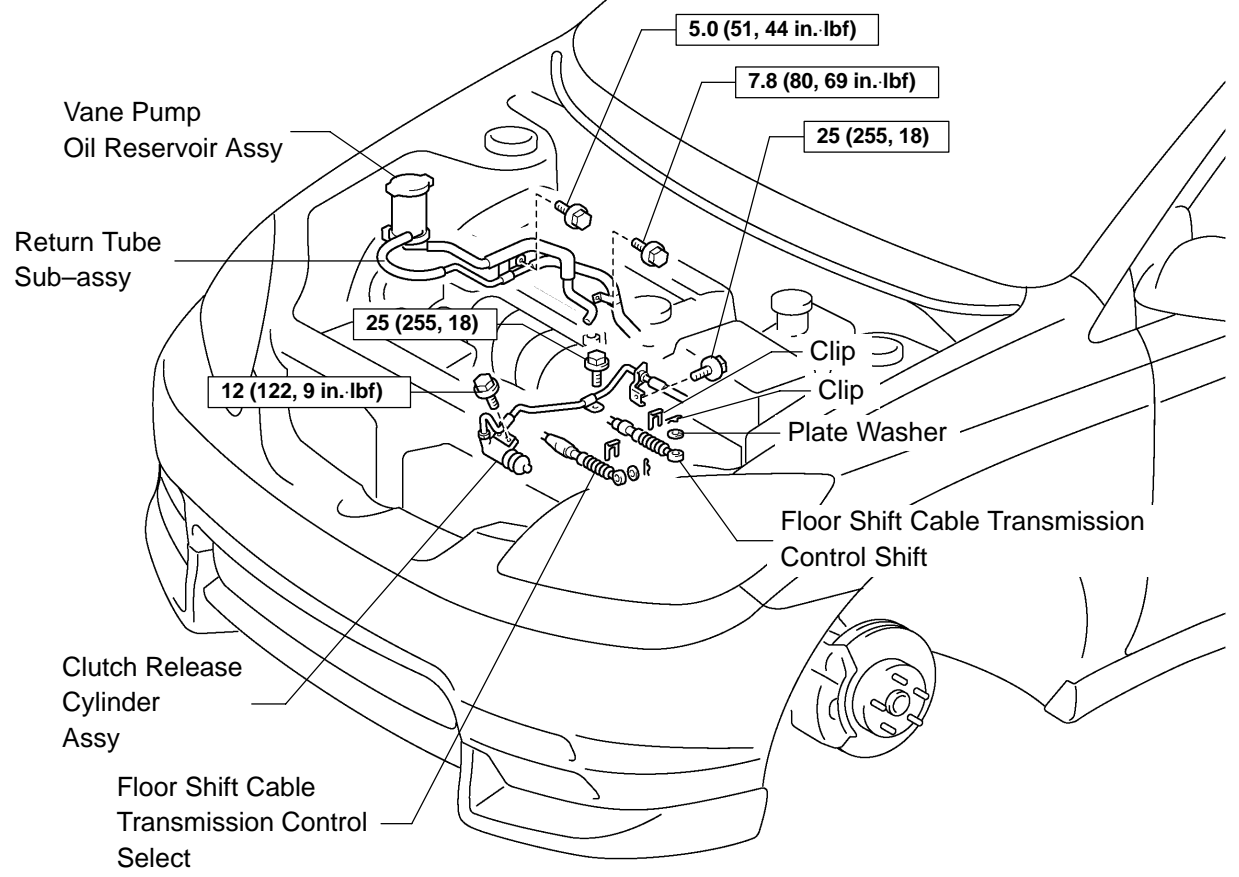
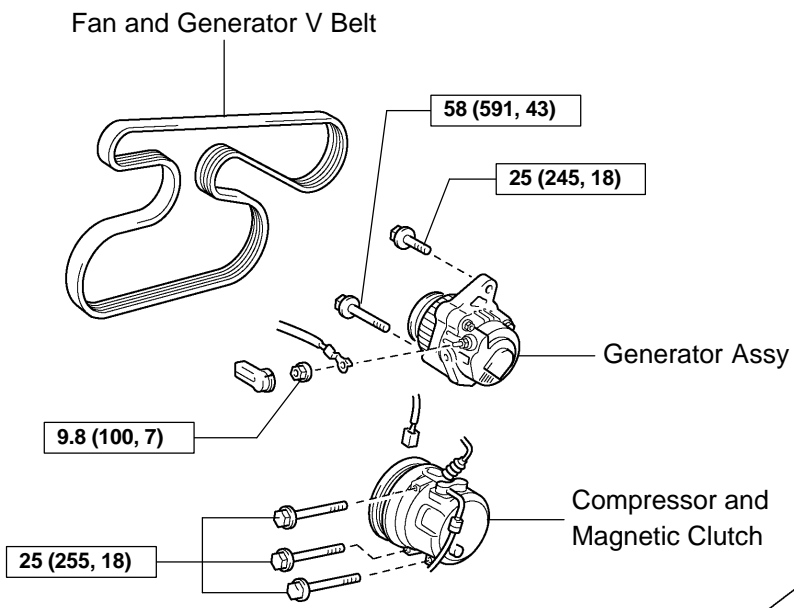
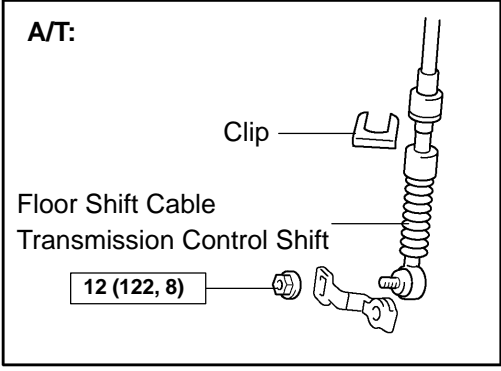

o [N·m (kgf·cm, ft·lbf)]: Specified torque

A65817

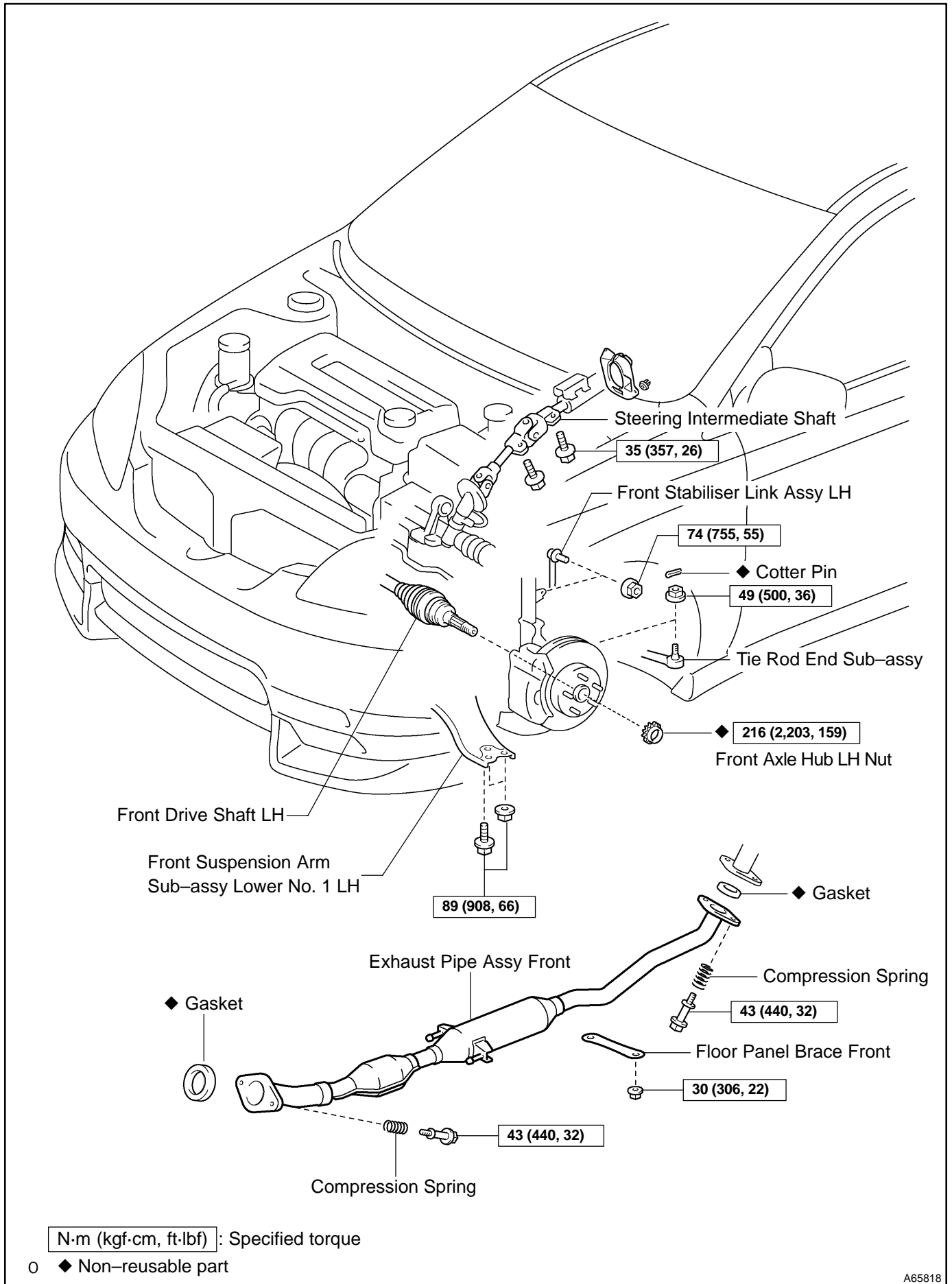

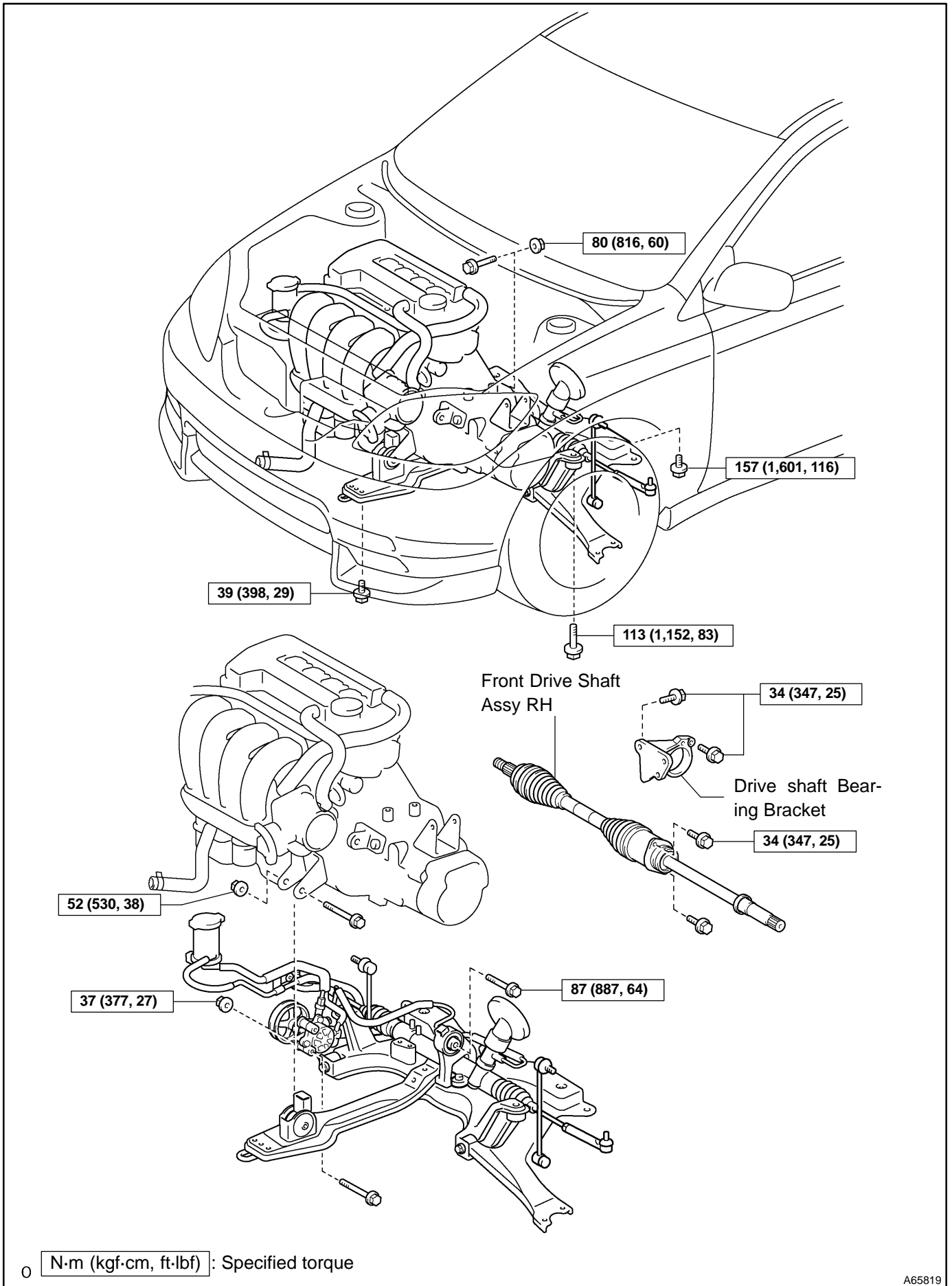

A65819

M/T:

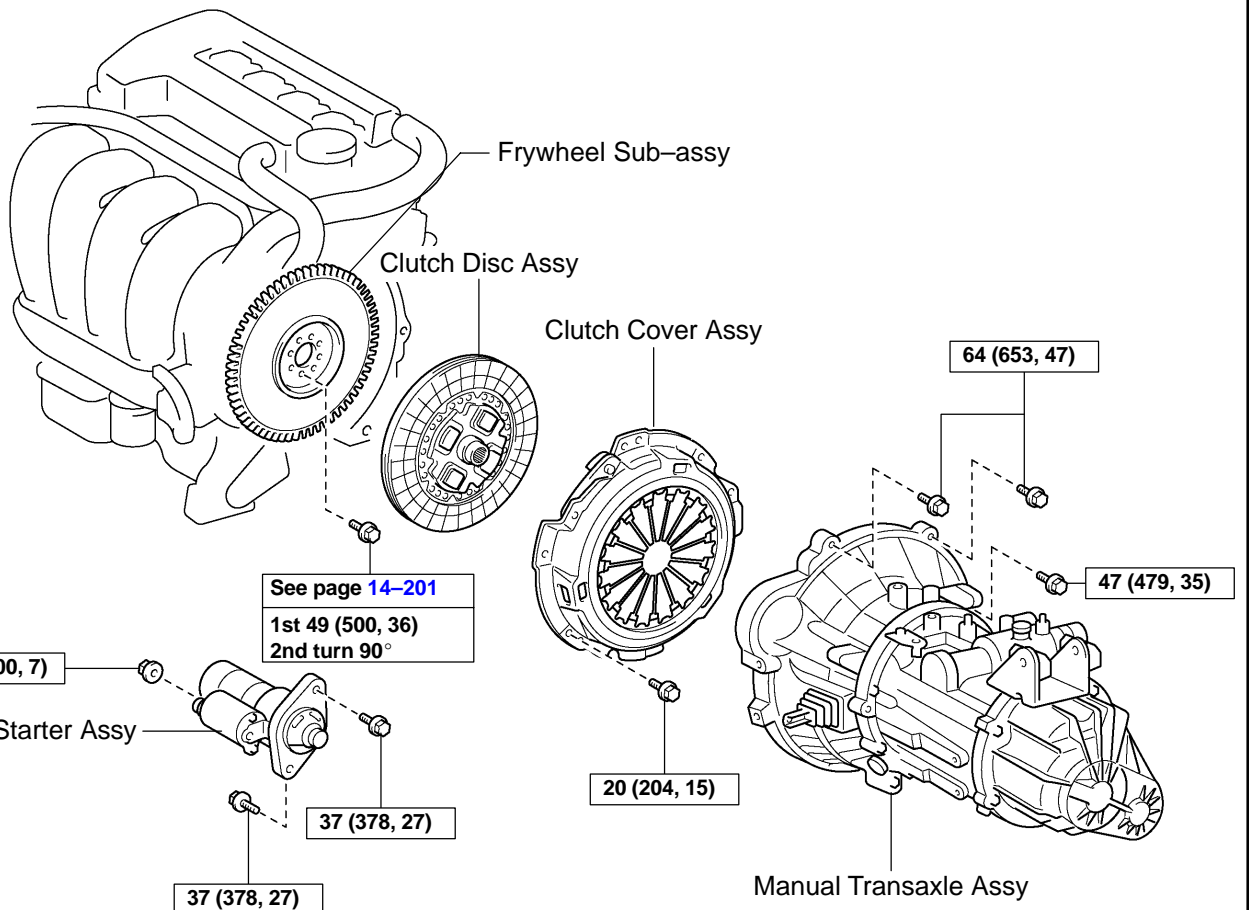
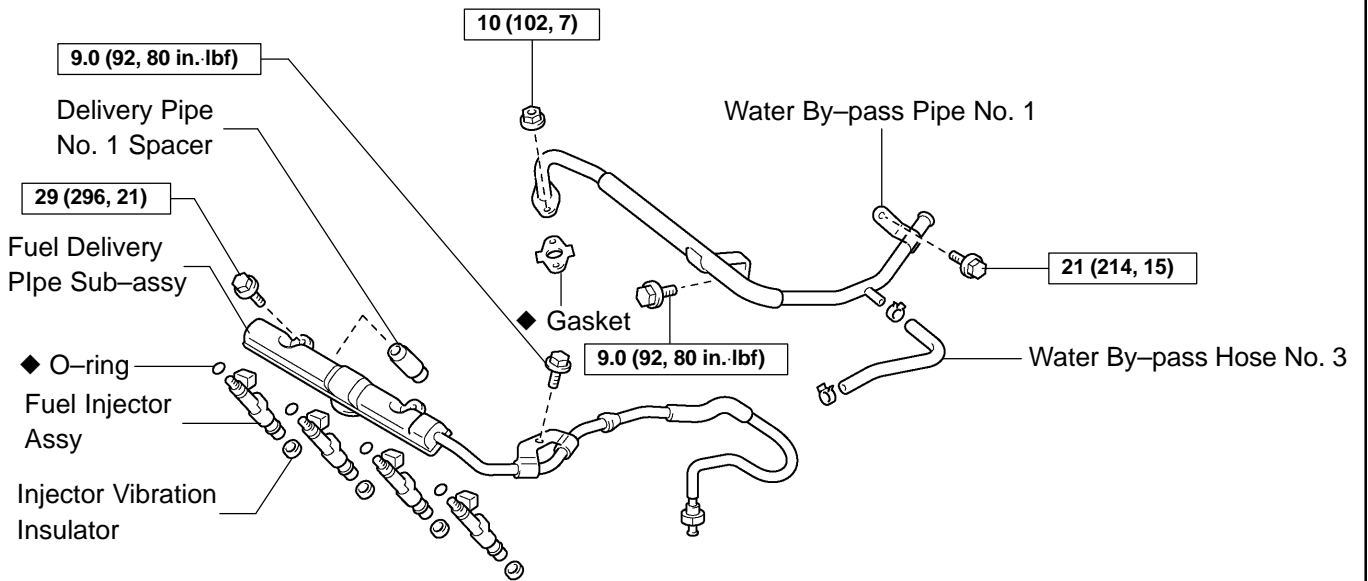

N·m (kgf·cm, ft·lbf) : Specified torque

◆ Non-reusable part

0

A65820

A/T:

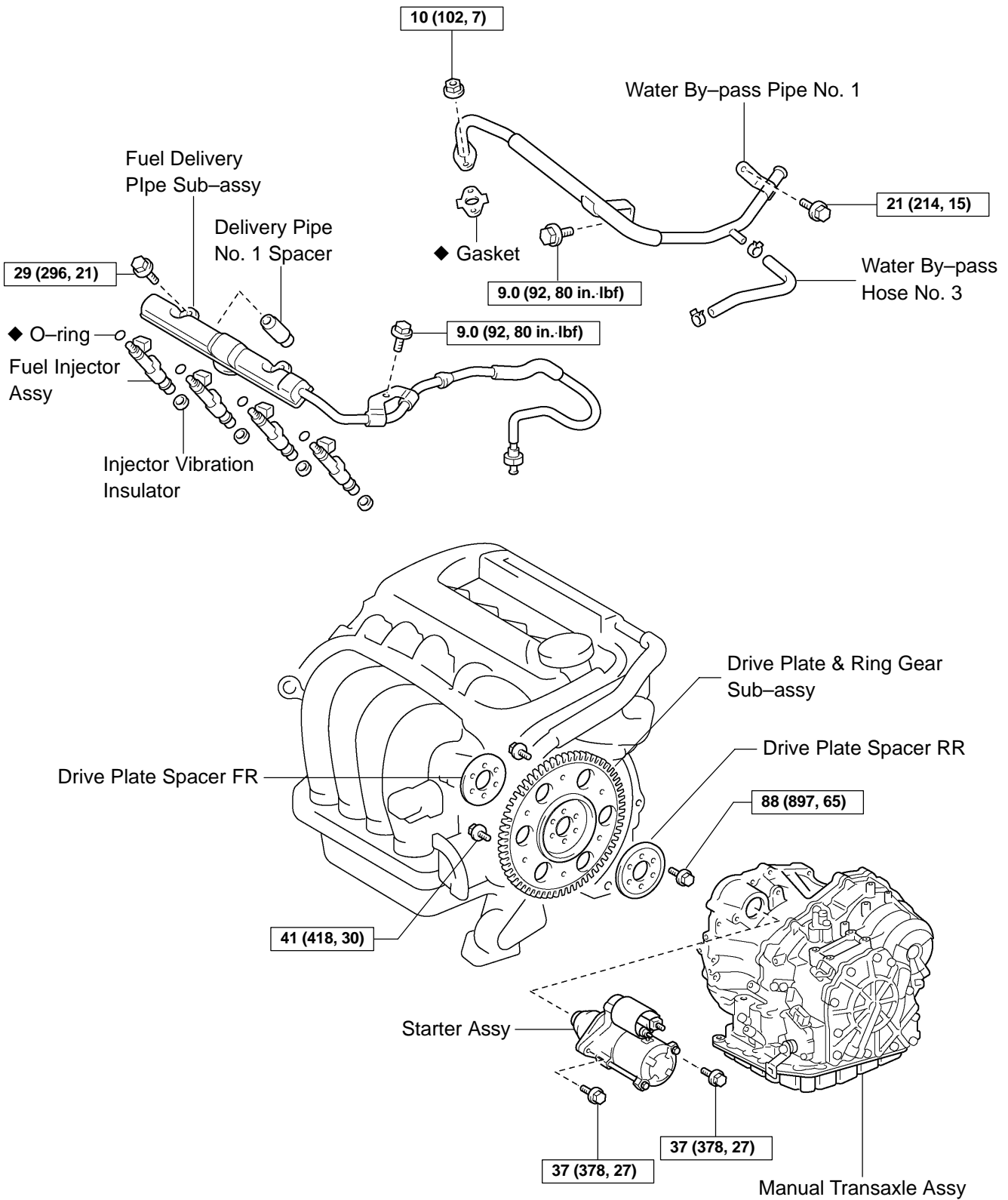

N·m (kgf·cm, ft·lbf) : Specified torque

o ◆ Non-reusable part

A65821

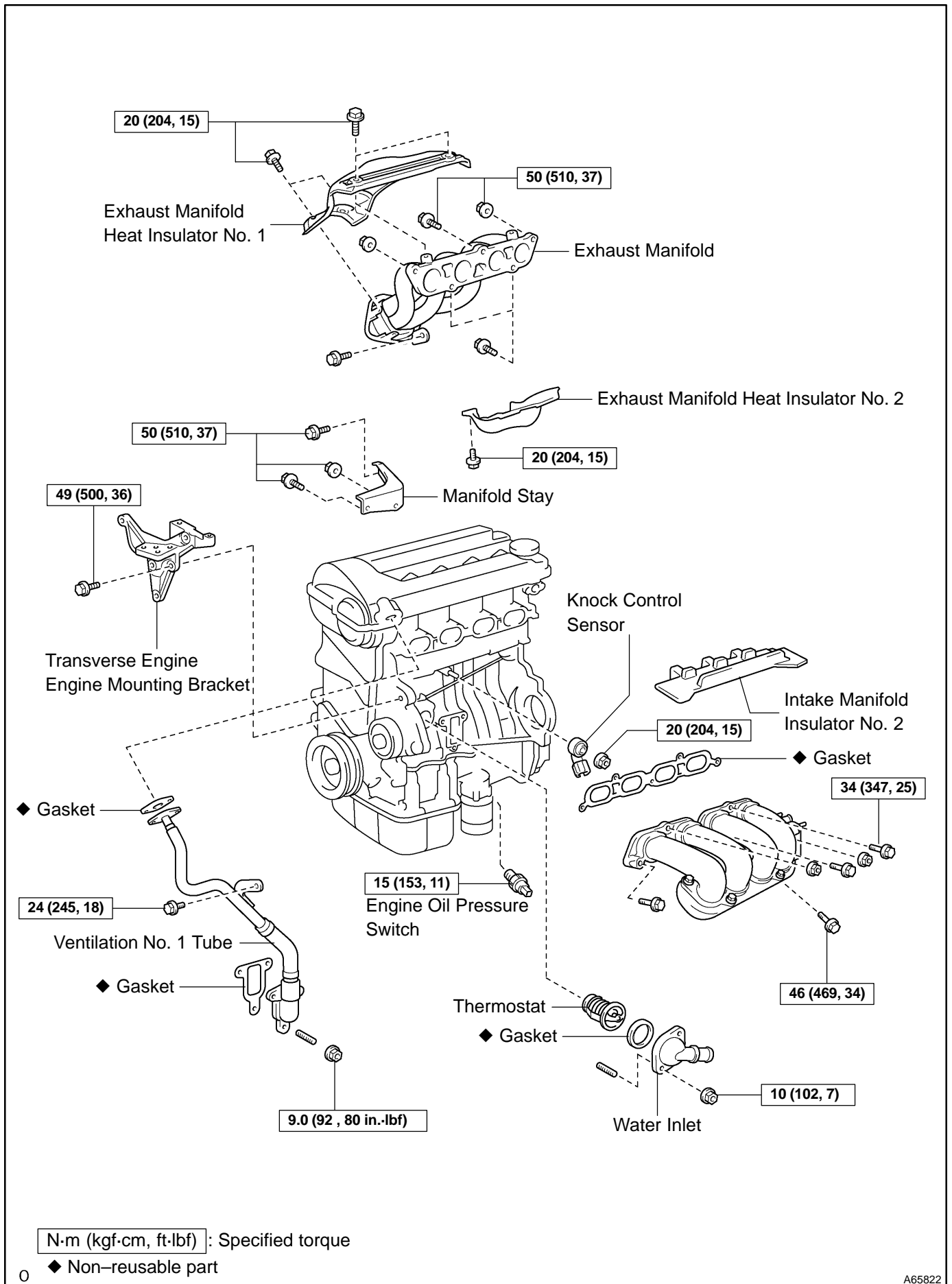

A65822

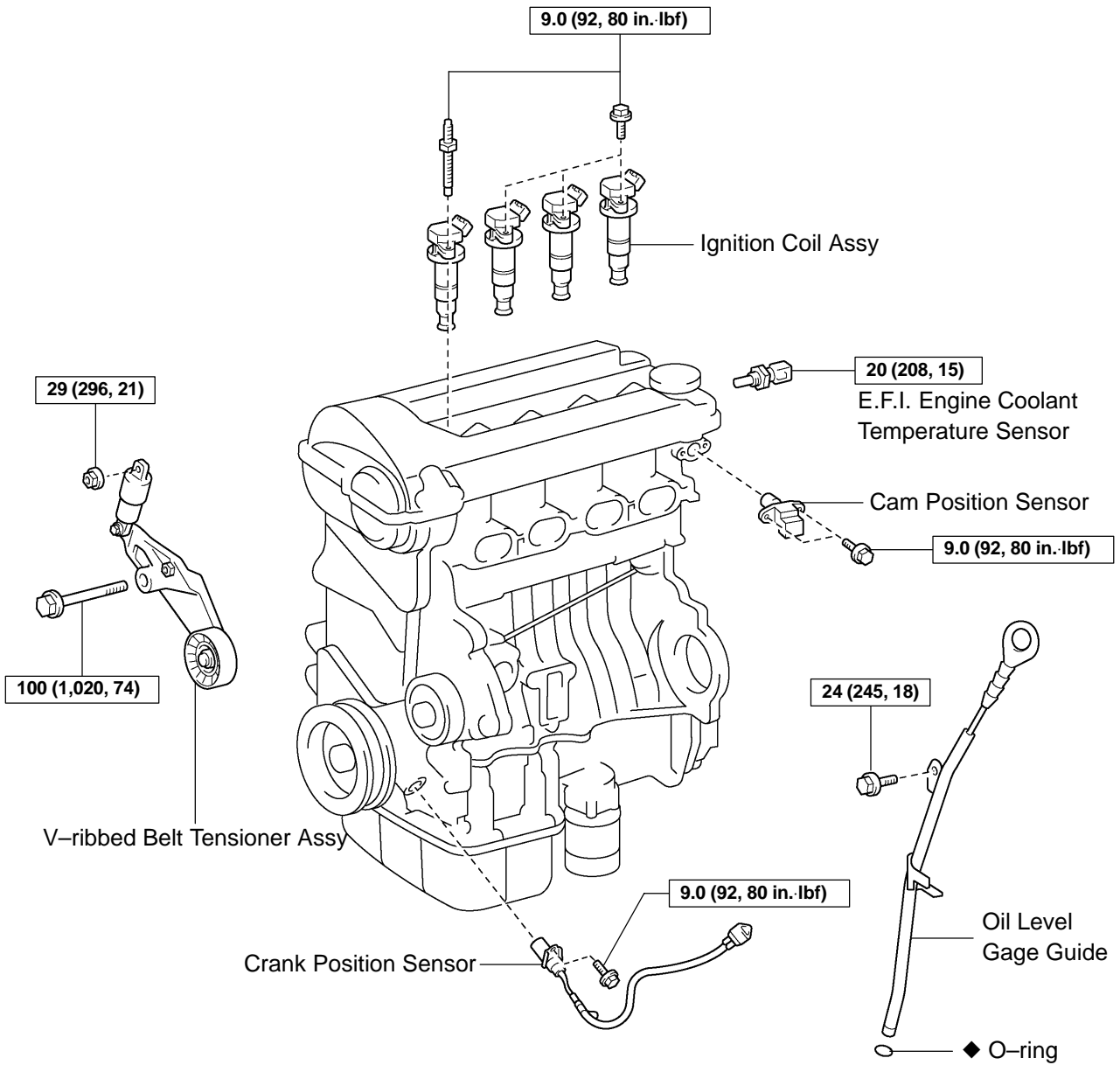

N·m (kgf·cm, ft·lbf) : Specified torque

◆ Non-reusable part

A65823

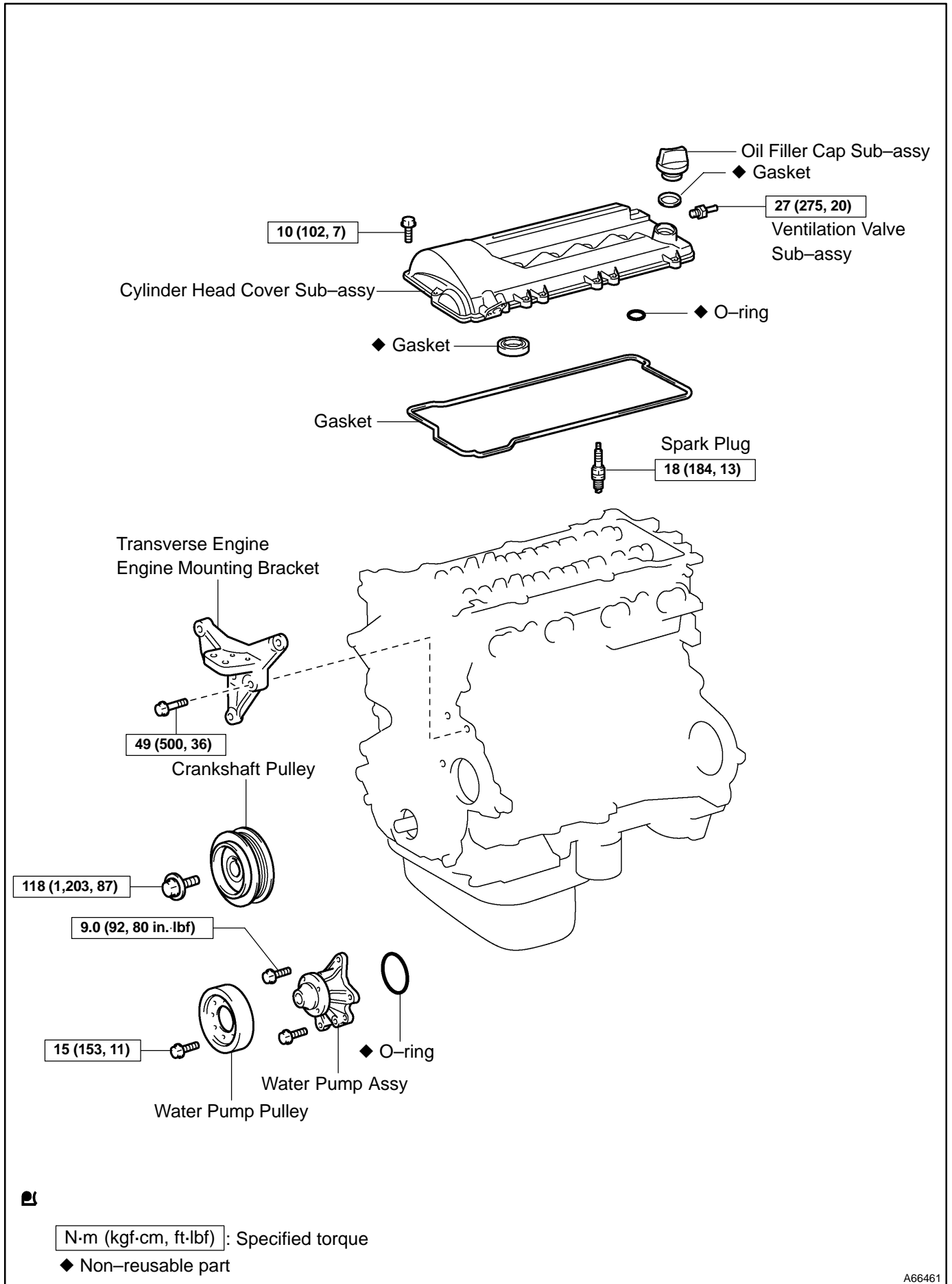

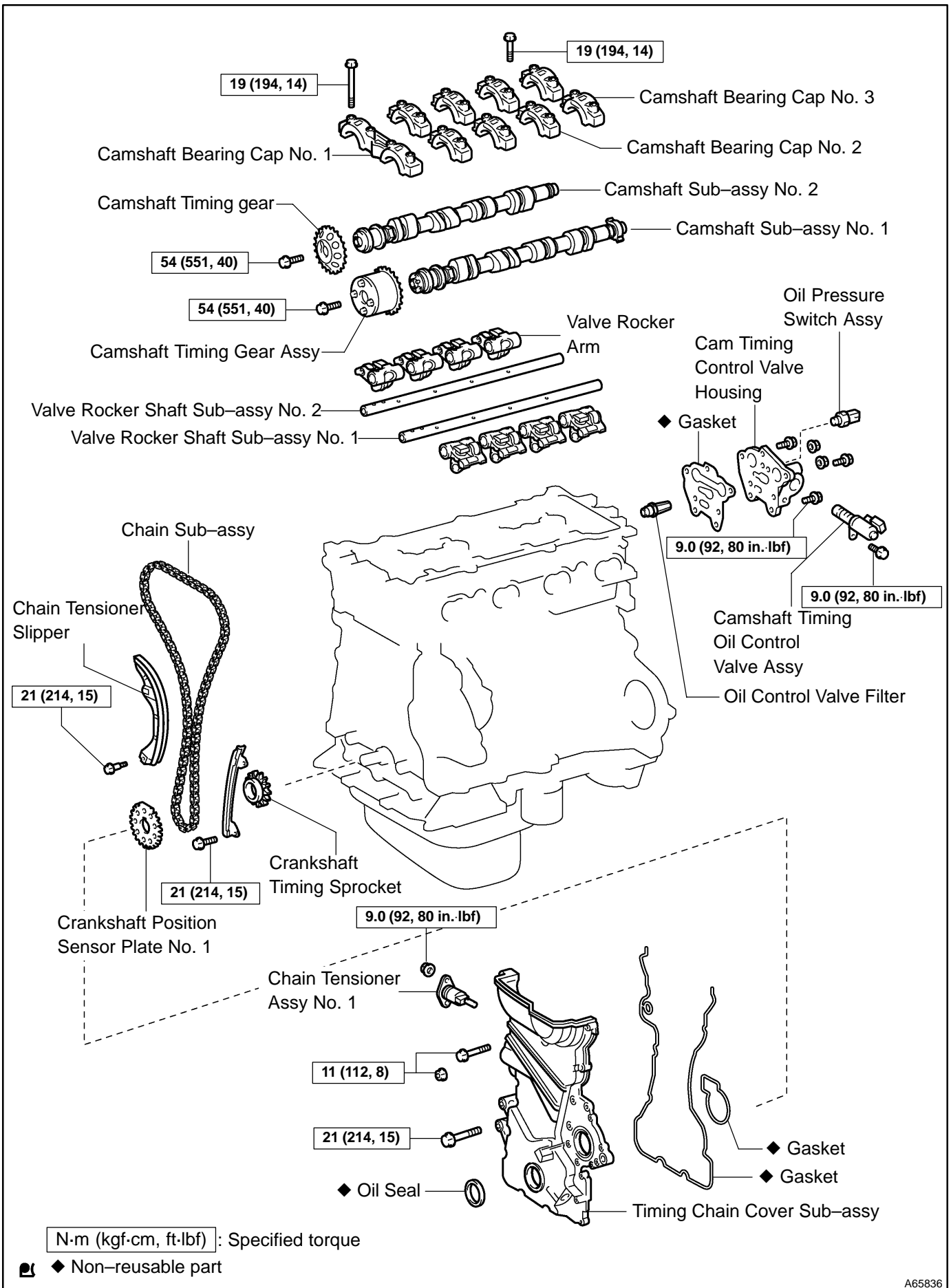

A65836

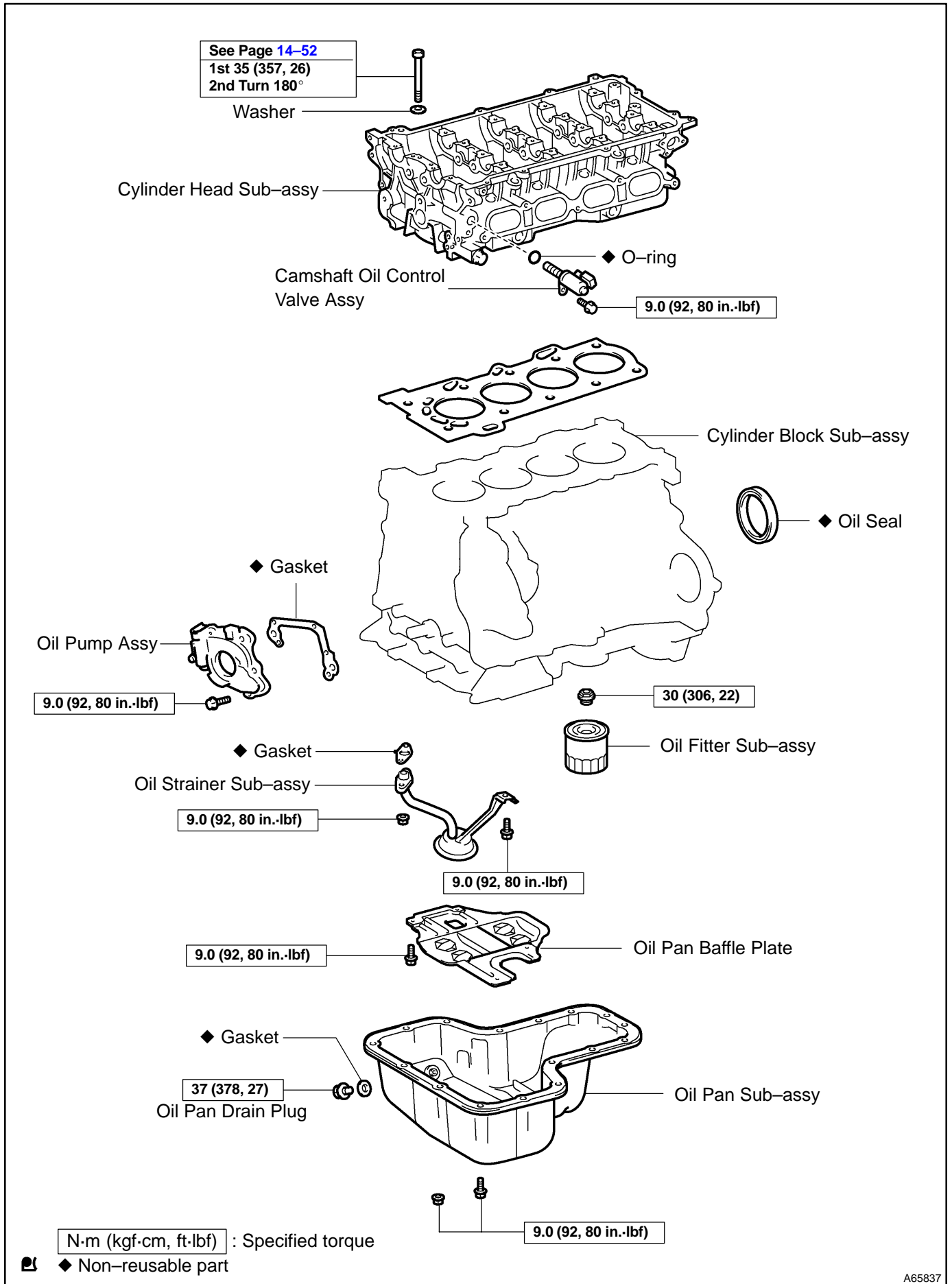

A65837