

INSPECTION PROCEDURE

| | |
|----------|--|
| 1 | CHECK P/T SQUIB(RH) CIRCUIT(AIRBAGA SENSOR ASSY CENTER – FRONT SEAT OUTER BELT ASSY RH) |
|----------|--|

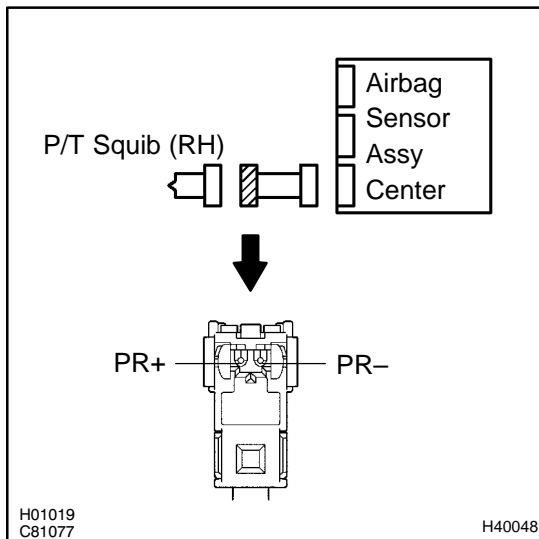

- (a) Disconnect the negative (-) terminal cable from the battery, and wait at least for 90 seconds.
- (b) Disconnect the connectors between the airbag sensor assy center and the seat belt pretensioner (RH).

HINT:

Make sure that the connector is not damaged (The lock button is not disengaged, or the claw of the lock is not deformed or damaged). If the damage is found, replace the wire harness.

- (c) Release the airbag activation prevention mechanism of the connector (on the airbag sensor assy center side) between the airbag sensor assy center and the seat belt pretensioner (RH) (See page 05-543).
- (d) For the connector (on the seat belt pretensioner side) between the airbag sensor assy center and the seat belt pretensioner (RH), measure the resistance between PR+ and PR-.

OK:

Resistance: 1 MΩ or Higher

NG

REPAIR OR REPLACE INSTRUMENT PANEL WIRE NO.3(AIRBAG SENSOR ASSY CENTER – FRONT SEAT OUTER BELT ASSY RH)

OK

2 CHECK AIR BAG SENSOR ASSY CENTER

SST 09843-18040

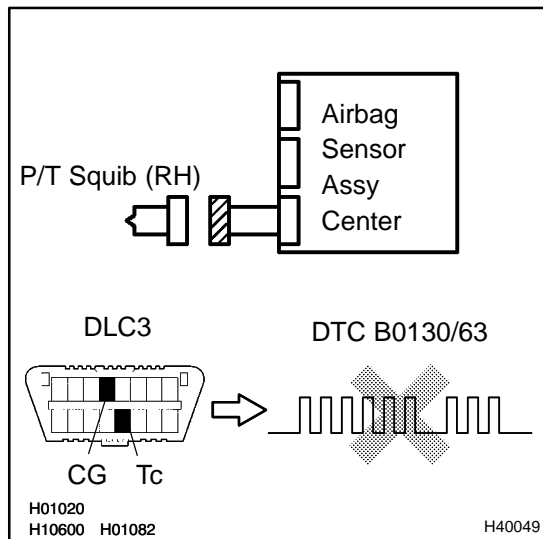

- Connect the connector to the airbag sensor assy center.
- Connect the negative (-) terminal cable to the battery, and wait at least for 2 seconds.
- Turn the ignition switch to ON, and wait at least for 20 seconds.
- Clear the DTC stored in memory (See page 05-543).
- Turn the ignition switch to LOCK, and wait at least for 20 seconds.
- Turn the ignition switch to ON, and wait at least for 20 seconds.
- Check the DTC (See page 05-543).

OK:**DTC B0130/63 is not output.****HINT:**

Codes other than code B0130/63 may be output at this time, but they are not relevant to this check.

NG**REPLACE AIR BAG SENSOR ASSY CENTER****OK**

3 CHECK P/T SQUIB (RH)

SST 09843-18040

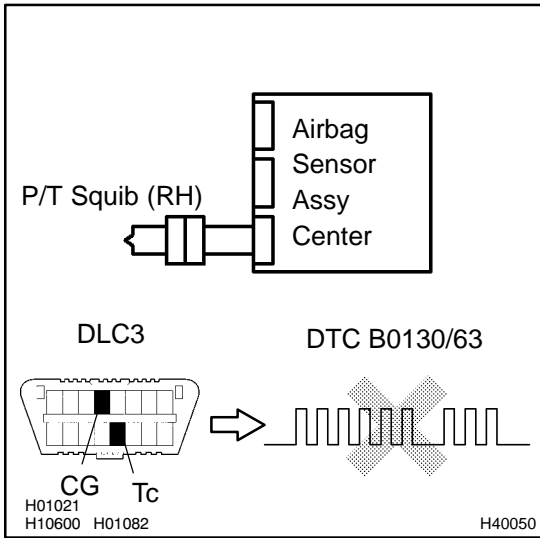

- (a) Turn the ignition switch to LOCK.
- (b) Disconnect the negative (-) terminal cable from the battery, and wait at least for 90 seconds.
- (c) Connect the seat belt pretensioner (RH) connector.
- (d) Connect the negative (-) terminal cable to the battery, and wait at least for 2 seconds.
- (e) Turn the ignition switch to ON, and wait at least for 20 seconds.
- (f) Clear the DTC stored in memory (See page 05-543).
- (g) Turn the ignition switch to LOCK, and wait at least for 20 seconds.
- (h) Turn the ignition switch to ON, and wait at least for 20 seconds.
- (i) Check the DTC (See page 05-543).

OK:

DTC B0130/63 is not output.

HINT:

Codes other than code B0130/63 may be output at this time, but they are not relevant to this check.

NG → **REPLACE FRONT SEAT OUTER BELT ASSY RH**

OK

USE SIMULATION METHOD TO CHECK