

DTC	P0500	VEHICLE SPEED SENSOR MALFUNCTION
------------	--------------	---

CIRCUIT DESCRIPTION

The vehicle speed sensor outputs a 4-pulse signal for every revolution of the rotor shaft, which is rotated by the transmission output shaft via the driven gear. After this signal is converted into a more precise rectangular waveform by the waveform shaping circuit inside the combination meter, it is then transmitted to the ECM. The ECM determines the vehicle speed based on the frequency of these pulse signals.

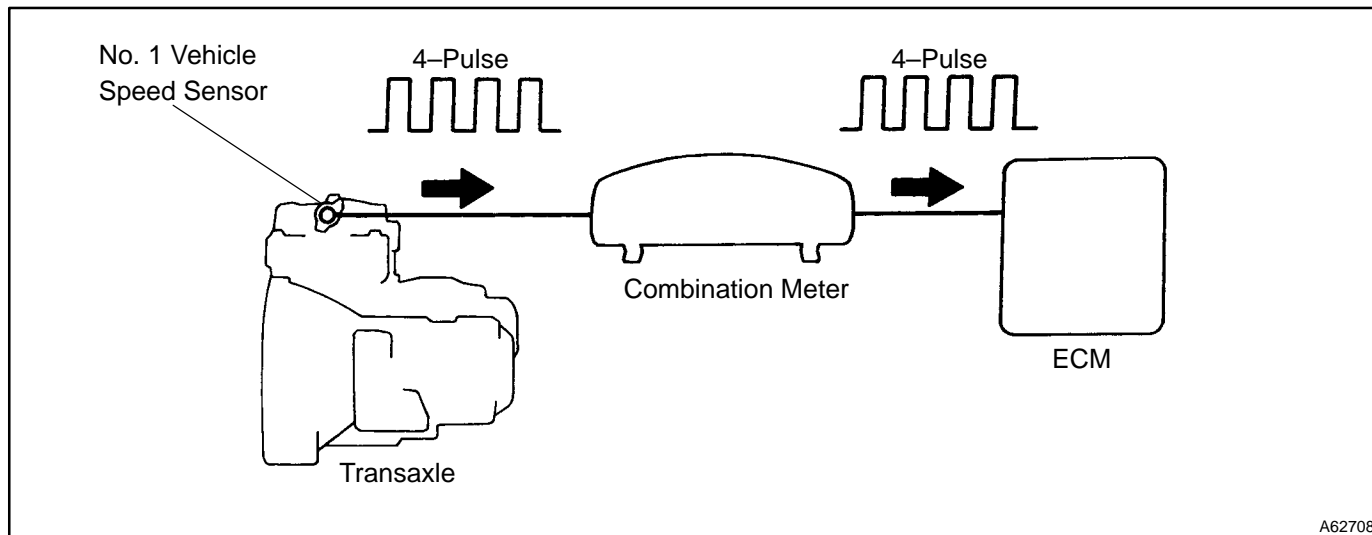

DTC No.	DTC Detecting Condition	Trouble Area
P0500	During vehicle is being driven, no vehicle speed sensor signal to ECM (2 trip detection logic)	<ul style="list-style-type: none"> • Combination meter • Open or short in vehicle speed sensor circuit • Vehicle speed sensor • ECM

WIRING DIAGRAM

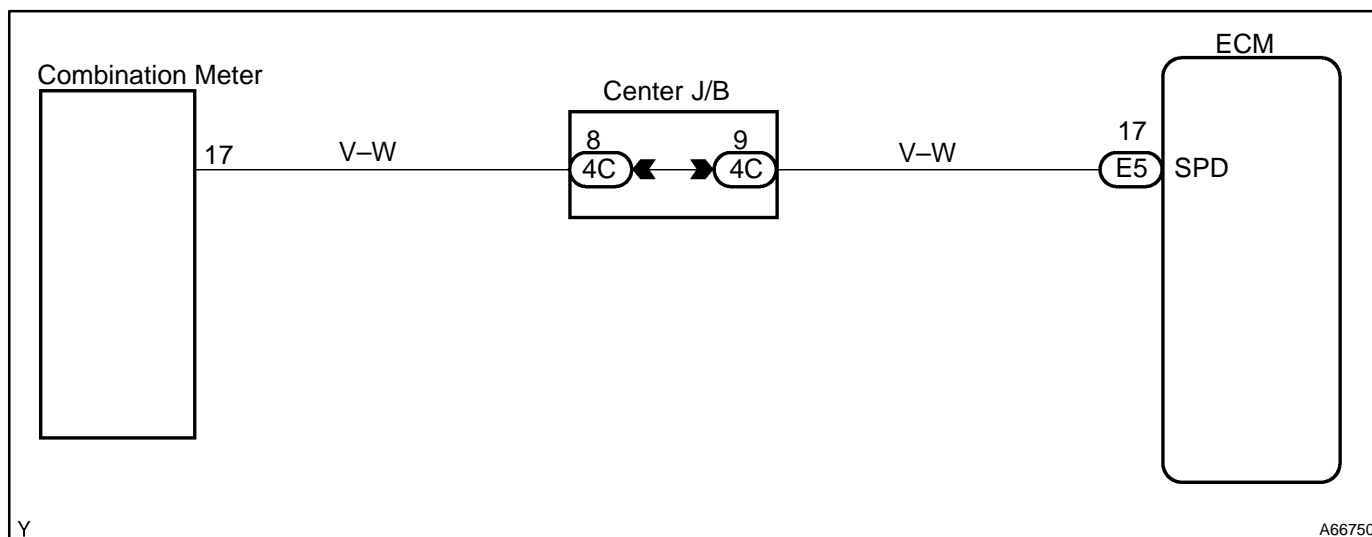

INSPECTION PROCEDURE

HINT:

HINT:Read freeze frame data using the hand-held tester or OBD II scan tool, as freeze frame data records the engine conditions when the malfunction is detected. When troubleshooting, it is useful for determining whether the vehicle was running or stopped, the engine was warmed up or not, the air-fuel ratio was lean or rich, etc. at the time of the malfunction.

1 CHECK OPERATION OF SPEEDOMETER

(a) Drive the vehicle and check if the operation of the speedometer in the combination meter is normal.

HINT:

The vehicle speed sensor is operating normally if the speedometer display is normal.

NG CHECK SPEEDOMETER CIRCUIT

OK

2 INSPECT ECM

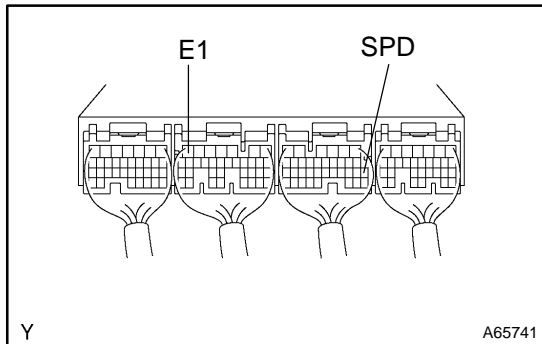

- (a) Shift the lever to the neutral position.
- (b) Jack up the vehicle.
- (c) Turn the ignition switch ON.
- (d) Measure the voltage between terminal SPD of the ECM connector and E1 of the ECM connector with turning the wheel slowly.

Voltage: Generated intermittently

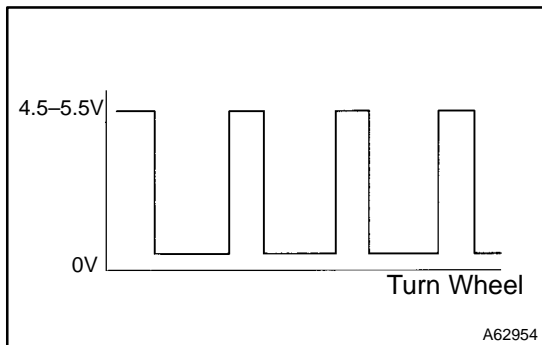

NG REPAIR OR REPLACE HARNESS AND CONNECTOR

OK

CHECK AND REPLACE ECM