

DTC	P0335	CRANKSHAFT POSITION SENSOR "A" CIRCUIT MALFUNCTION
------------	--------------	---

CIRCUIT DESCRIPTION

Crankshaft position sensor (NE signal) consists of a magnet, iron core and pick up coil. The NE signal plate (crank angle sensor plate) has 34 teeth and is mounted on the crankshaft. The NE signal sensor generates 34 signals at every engine revolution. The ECM detects the standard crankshaft angle based on the G signal, the actual crankshaft angle and the engine speed by the NE signal.

DTC No.	DTC Detecting Condition	Trouble Area
P0335	No crankshaft position sensor signal to ECM during cranking (2 trip detection logic)	<ul style="list-style-type: none"> • Open or short in crankshaft position sensor circuit • Crankshaft position sensor • Crank angle sensor plate • ECM
	No crankshaft position sensor signal to ECM with engine speed 600 rpm or more (2 trip detection logic)	

WIRING DIAGRAM

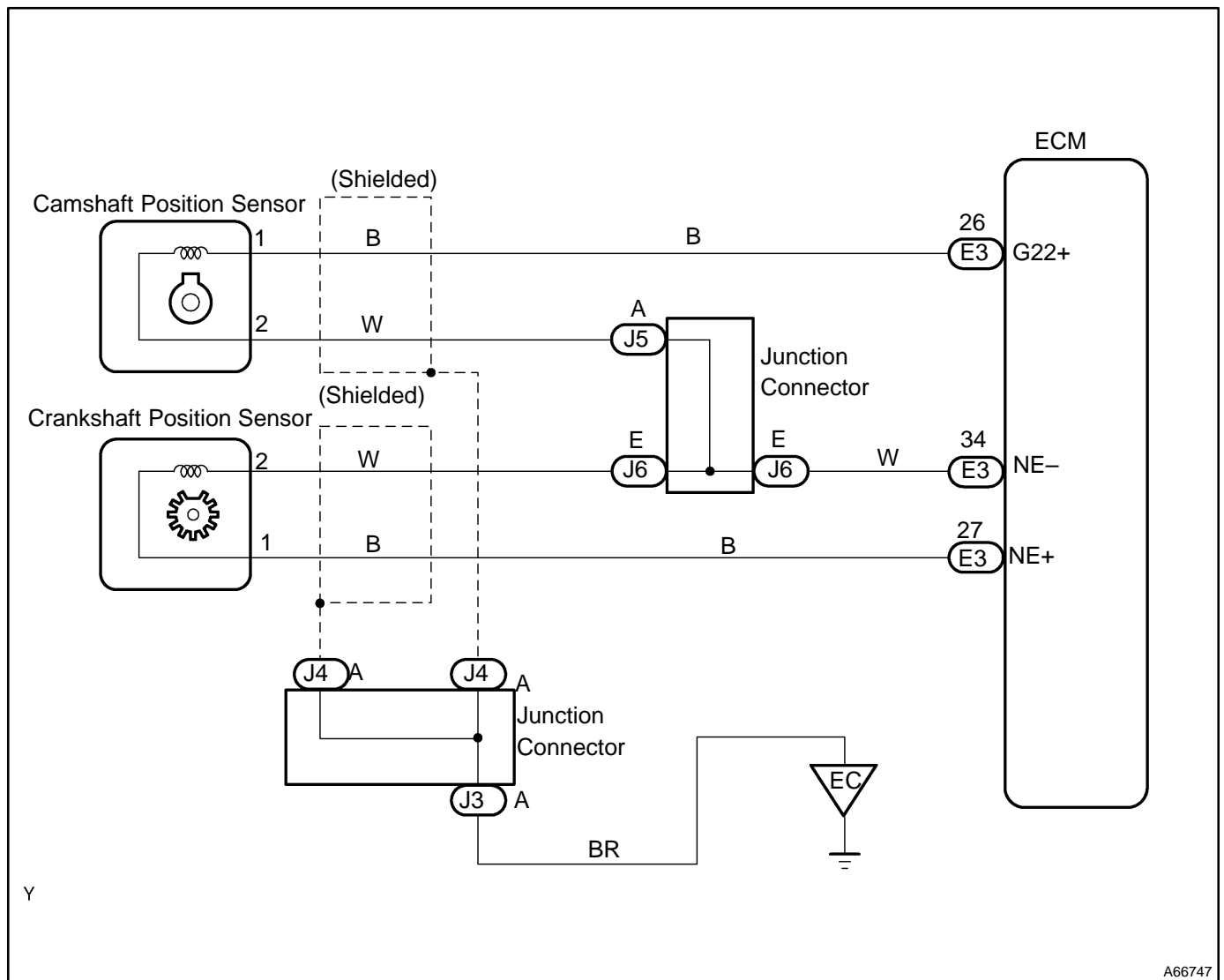

Y

A66747

INSPECTION PROCEDURE

HINT:

- Read freeze frame data using hand-held tester or OBD II scan tool. Because freeze frame records the engine conditions when the malfunction is detected, when troubleshooting it is useful for determining whether the vehicle was running or stopped, the engine warmed up or not, the air-fuel ratio lean or rich, etc. at the time of the malfunction.
- Perform troubleshooting of DTC P0335 first. If no trouble is found, troubleshoot the following mechanical system.

1 INSPECT CRANK POSITION SENSOR

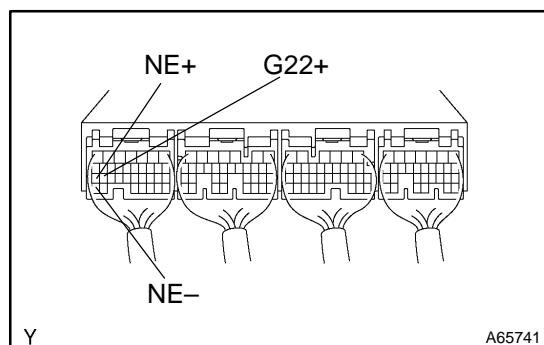

- (a) Check the crankshaft position sensor for resistance.

Resistance:

985 – 1600 Ω (Cold)

1265 – 1890 Ω (Hot)

HINT:

"Cold" and "Hot" above express the temperature of the part itself. "Cold" is from -10°C (14°F) to 50°C (122°F) and "Hot" is from 50°C (122°F) to 100°C (212°F).

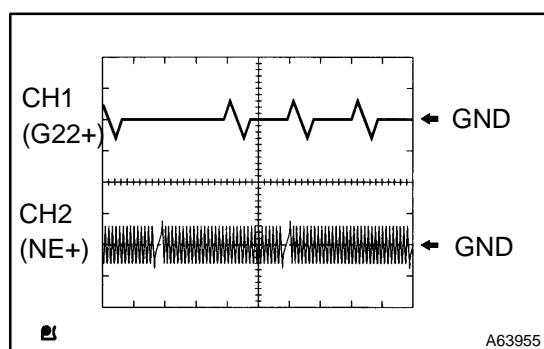

- (b) Reference:

Inspection using the oscilloscope.

- (1) During cranking or idling, check the wave form between terminals G22+ and NE-, and NE+ and NE- of the ECM connector.

HINT:

The correct wave forms are as shown in the left.

NG

REPLACE CRANK POSITION SENSOR

OK

2 CHECK HARNESS AND CONNECTOR(ECM-CRANKSHAFT POSITION SENSOR)

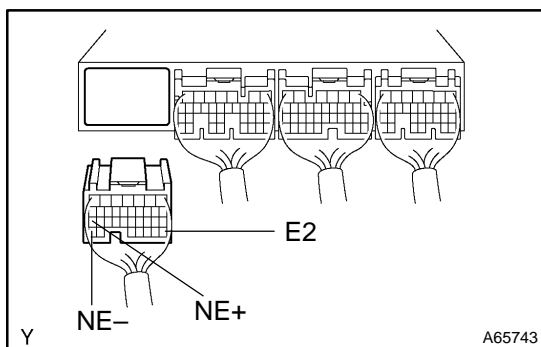
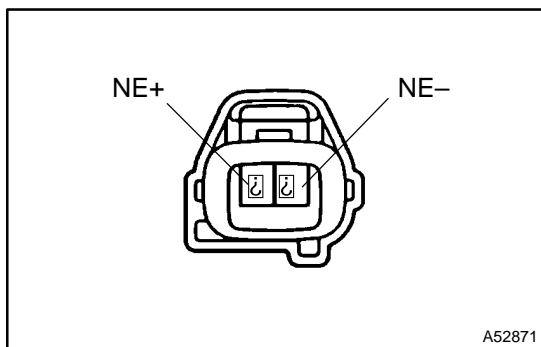

- (a) Disconnect the crank position sensor connector.
- (b) Disconnect the ECM E3 connector.
- (c) Check continuity between the terminals NE+ of the crank position sensor connector and NE+ of the ECM connector.
Resistance: 1 Ω or less
- (d) Check for short between the terminals NE+ and E2 of the ECM connector.
Resistance: 1 MΩ or more
- (e) Check continuity between the terminals NE- of the crank position sensor connector and NE- of the ECM connector.
Resistance: 1 Ω or less
- (f) Check for short between the terminals NE- and E2 of the ECM connector.
Resistance: 1 MΩ or more

NG

REPAIR OR REPLACE HARNESS AND CONNECTOR

OK

3 INSPECT SENSOR ATTACHMENT PART

- (a) Check the crank position sensor installation .

NG

REPAIR OR REPLACE SENSOR ATTACHMENT PART

OK

4 INSPECT CRANKSHAFT POSITION SENSOR PLATE NO.1(TEETH OF SIGNAL PLATE)

- (a) Remove the crank angle sensor plate.
- (b) Check the teeth of the signal plate.

NG

REPAIR OR REPLACE CRANKSHAFT POSITION SENSOR PLATE NO.1

OK

CHECK AND REPLACE ECM