

DTC	P0110	INTAKE AIR TEMP. CIRCUIT MALFUNCTION
------------	--------------	---

CIRCUIT DESCRIPTION

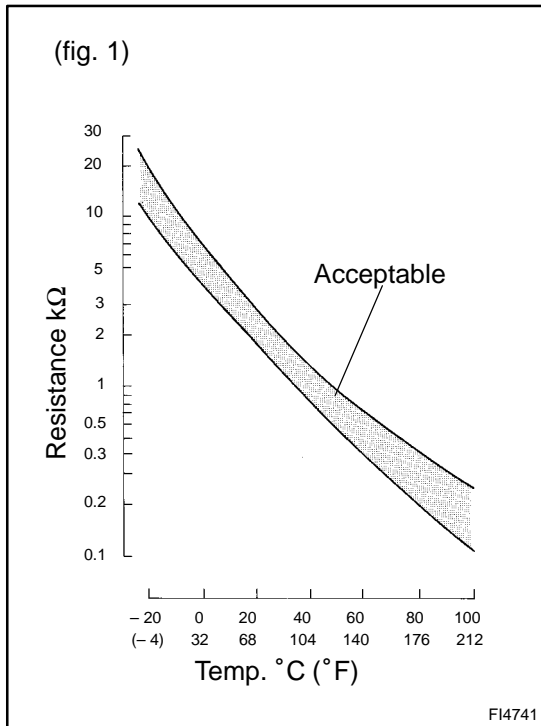

The intake air temp. sensor is built into the mass air flow meter and senses the intake air temperature. A thermistor built in the sensor changes the resistance value according to the intake air temperature. The lower the intake air temperature, the greater the thermistor resistance value, and the higher the intake air temperature, the lower the thermistor resistance value (See fig. 1). The intake air temp. sensor is connected to the ECM (See below). The 5 V power source voltage in the ECM is applied to the intake air temp. sensor from the terminal THA via resistor R. That is, the resistor R and the intake air temp. sensor are connected in series. When the resistance value of the intake air temp. sensor changes in accordance with changes in the intake air temperature, the potential at terminal THA also changes. Based on this signal, the ECM increases the fuel injection volume to improve driveability during cold engine operation. If the ECM detects the DTC "P0110", it operates the fall safe function in which the intake air temperature is assumed to be 20°C (68°F).

DTC No.	DTC Detecting Condition	Trouble Area
P0110	Open or short in intake air temp. sensor circuit	<ul style="list-style-type: none"> • Open or short in intake air temp. sensor circuit • Intake air temp. sensor (inside mass air flow meter) • ECM

WIRING DIAGRAM

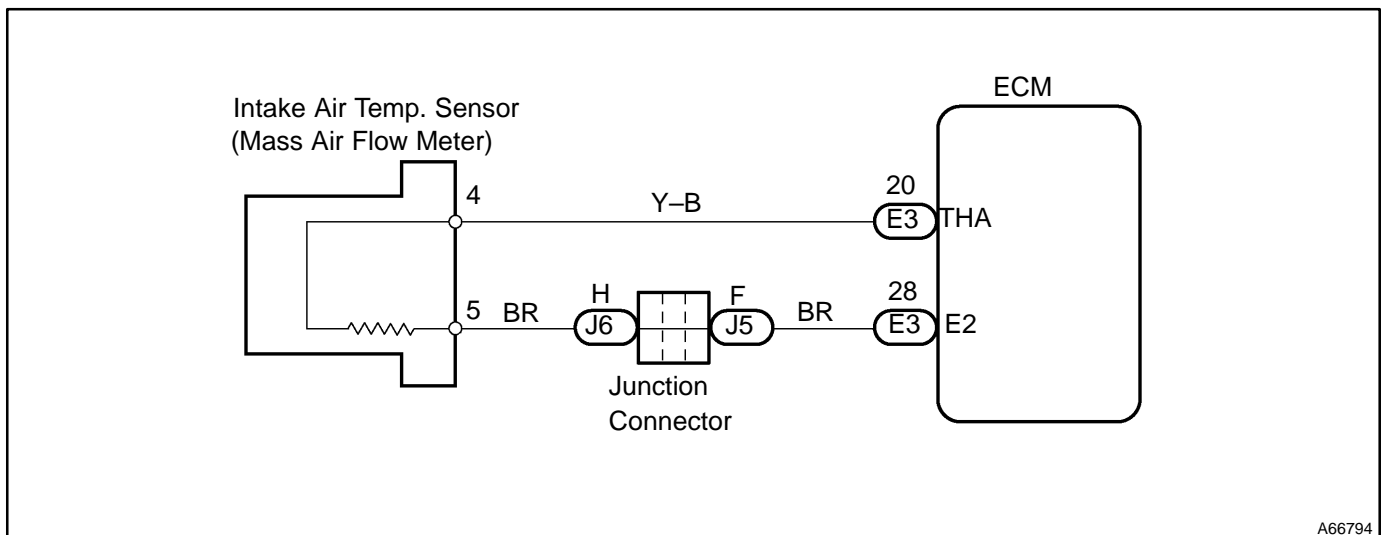

INSPECTION PROCEDURE

HINT:

- If DTCs P0100, P0101, P0110, P0115, P0116, P120 and P0121 are output simultaneously, E2 (sensor ground) may be open.
- Read freeze frame data using hand-held tester or OBD II scan tool. Because freeze frame records the engine conditions when the malfunction is detected, when troubleshooting it is useful for determining whether the vehicle was running or stopped, the engine warmed up or not, the air-fuel ratio lean or rich, etc. at the time of the malfunction.

1 READ VALUE OF OBD II SCAN TOOL OR HAND-HELD TESTER(INTAKE AIR TEMPERATURE)

- (a) Read temperature value on the hand-held tester or OBD II scan tool.

Temperature: The same as actual intake air temperature

Result:

A	B	C
-40°C (-40°F)	140°C (284°F) or more	OK

B

Go to step 4

C

CHECK FOR INTERMITTENT PROBLEMS

A

2 READ VALUE OF OBD II SCAN TOOL OR HAND-HELD TESTER(CHECK FOR OPEN IN HARNESS)

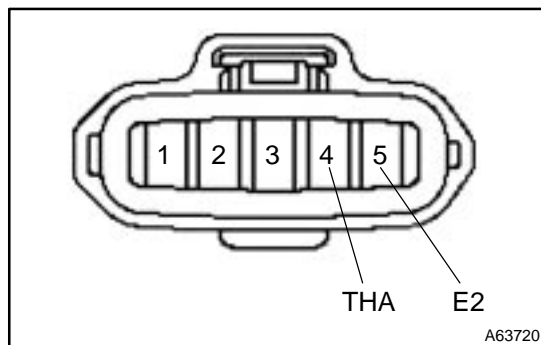

- (a) Disconnect the mass air flow meter connector.
 (b) Connect the terminal THA with E2.
 (c) Turn the ignition switch ON.
 (d) Read temperature value on the hand-held tester or OBD II scan tool.

Temperature: 140°C (284°F) or more

OK

REPLACE INTAKE AIR FLOW METER SUB-ASSY

NG

3 READ VALUE OF OBD II SCAN TOOL OR HAND-HELD TESTER(CHECK FOR OPEN IN ECM)

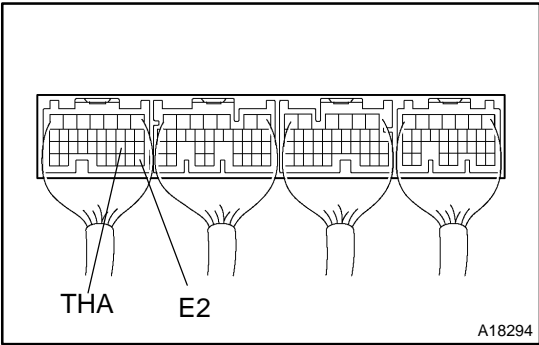

- (a) Disconnect the mass air flow meter connector.
 - (b) Turn the ignition switch ON.
 - (c) Connect the terminals THA with E2 of the ECM connector.
- HINT:
Before checking, do a visual check and connector connection and terminal inspection of the ECM.
- (d) Read temperature value on the hand-held tester or OBD II scan tool.

Temperature: 140°C (284°F) or more

NG → CHECK AND REPLACE ECM

OK

READ VALUE OF HARNESS AND CONNECTOR

4 READ VALUE OF OBD II SCAN TOOL OR HAND-HELD TESTER(CHECK FOR SHORT IN HARNESS)

- (a) Disconnect the mass air flow meter connector.
 - (b) Turn the ignition switch ON.
 - (c) Read temperature value on the hand-held tester or OBD II scan tool.
- Temperature: -40°C (-40°F)**

OK → REPLACE INTAKE AIR FLOW METER SUB-ASSY

NG

5 READ VALUE OF OBD II SCAN TOOL OR HAND-HELD TESTER(CHECK FOR SHORT IN ECM)

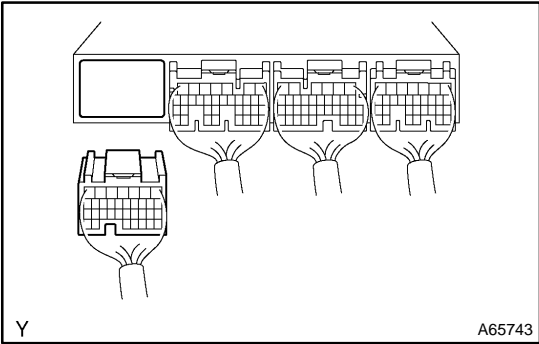

- (a) Disconnect the the ECM E3 connector.
 - (b) Turn the ignition switch ON.
 - (c) Read temperature value on the hand-held tester or OBD II scan tool.
- Temperature: -40°C (-40°F)**

OK → REPAIR OR REPLACE HARNESS AND CONNECTOR

NG

CHECK AND REPLACE ECM