

<b>DTC</b>	<b>P0100</b>	<b>MASS AIR FLOW CIRCUIT MALFUNCTION</b>
------------	--------------	--

**CIRCUIT DESCRIPTION**

The mass air flow meter uses a platinum hot wire. The hot wire air flow meter consists of a platinum hot wire, thermistor and a control circuit installed in a plastic housing. The hot wire air flow meter works on the principle that the hot wire and thermistor located in the intake air bypass of the housing detect any changes in the intake air temperature.

The hot wire is maintained at the set temperature by controlling the current flow through the hot wire. This current flow is then measured as the output voltage of the air flow meter.

The circuit is constructed so that the platinum hot wire and thermistor provide a bridge circuit, with the power transistor controlled so that the potential of A and B remains equal to maintain the set temperature.

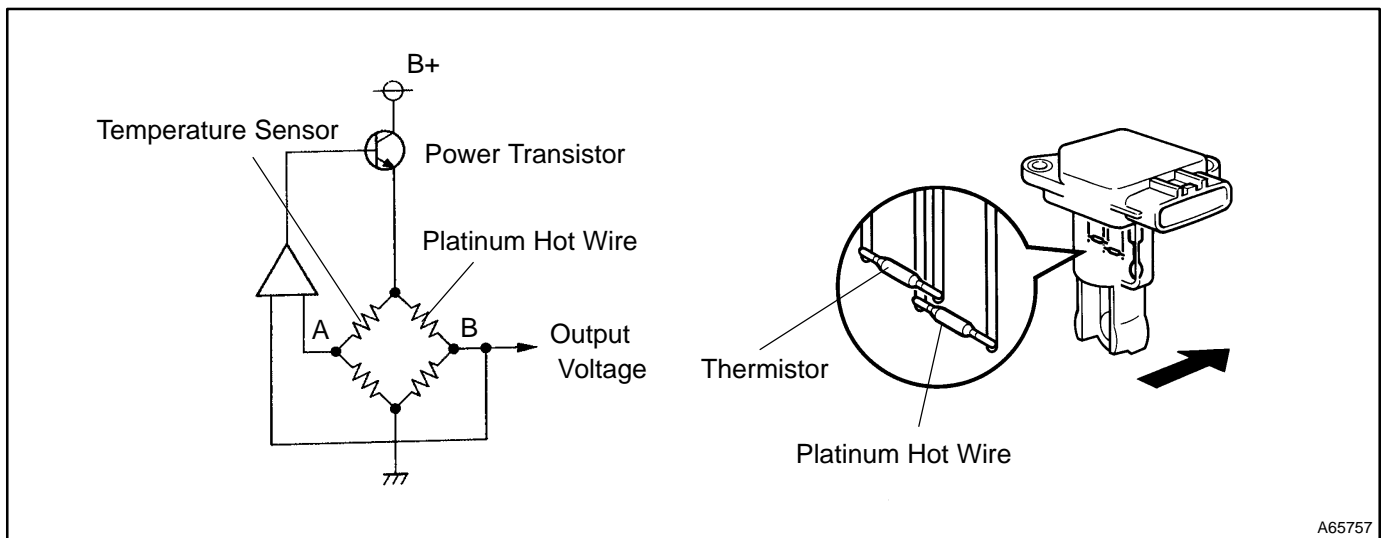

A65757

DTC No	DTC Detecting Condition	Trouble Area
P0100	Open or short in air flow meter circuit with more than 3 sec. engine speed less than 4,000 rpm	<ul style="list-style-type: none"> <li>• Open or short in air flow meter circuit</li> <li>• Air flow meter</li> <li>• ECM</li> </ul>

If the ECM detects DTC "P0100" it operates the fail-safe function, keeping the ignition timing and injection volume constant and making it possible to drive the vehicle.

**HINT:**

After confirming DTC P0100, use the OBD II scan tool or hand-held tester to confirm the air flow ratio from CURRENT DATA.

Mass Air Flow Value (gm/sec.)	Malfunction
Approx. 0.0	<ul style="list-style-type: none"> <li>• Mass air flow meter power source circuit open</li> <li>• VG circuit open or short</li> </ul>
271.0 or more	<ul style="list-style-type: none"> <li>• EVG circuit open</li> </ul>

**WIRING DIAGRAM**

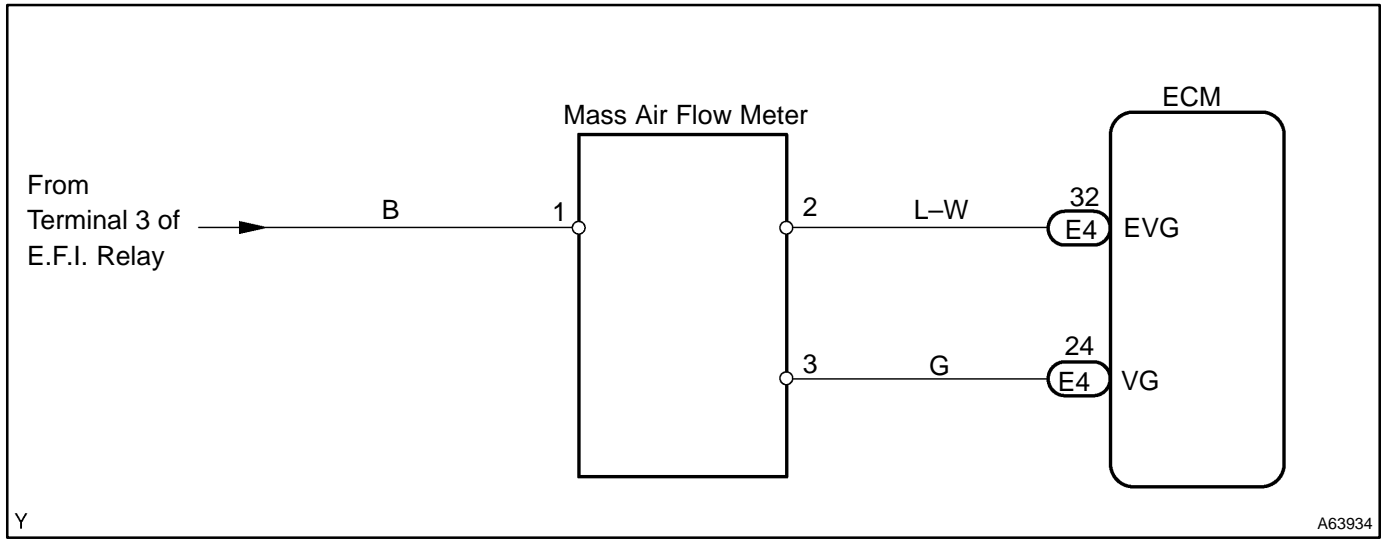

**INSPECTION PROCEDURE**

**HINT:**

Read freeze frame data using hand-held tester or OBD II scan tool. Because freeze frame records the engine conditions when the malfunction is detected, when troubleshooting it is useful for determining whether the vehicle was running or stopped, the engine warmed up or not, the air-fuel ratio lean or rich, etc. at the time of the malfunction.

**1 READ VALUE OF OBD II SCAN TOOL OR HAND-HELD TESTER(MASS AIR FLOW RATE)**

(a) Read mass air flow rate on the hand-held tester or OBD II scan tool.

**Result:**

	A	B
Mass air flow rate (gm/sec.)	0.0	271.0 or more

**B** → Go to step 6

**A**

**2 INSPECT INTAKE AIR FLOW METER SUB-ASSY(POWER SOURCE VOLTAGE)**

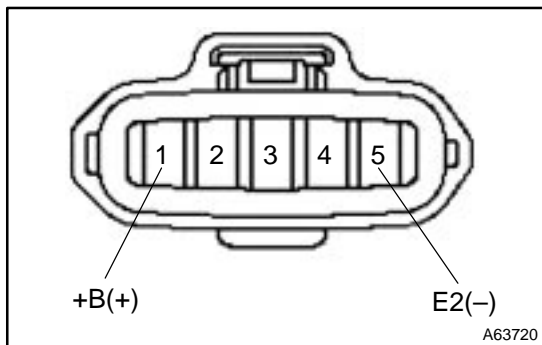

- (a) Disconnect the mass air flow meter connector.
- (b) Turn the ignition switch ON.
- (c) Measure voltage between the terminals +B and E2 of the mass air flow meter connector.

**Voltage: 9 - 14 V**

**NG** → Go to step 5

**OK**

**3 INSPECT ECM**

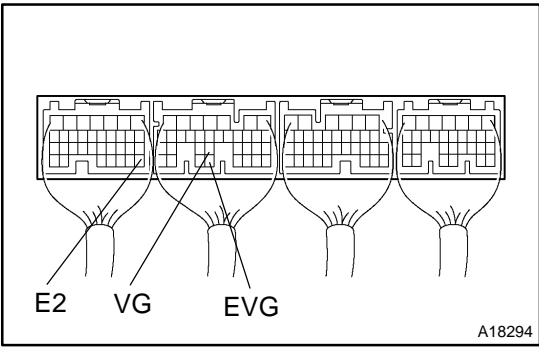

- (a) Turn the ignition switch ON.
- (b) Measure voltage between the terminals VG and EVG of the ECM connector while the engine is idling.

**Voltage: 0.5 – 3.0 V**

HINT:  
The shift position should be P or N and A/C switch should be turned OFF.

**NG** CHECK AND REPLACE ECM

**OK**

**4 CHECK HARNESS AND CONNECTOR(ECM-MASS AIR FLOW METER)**

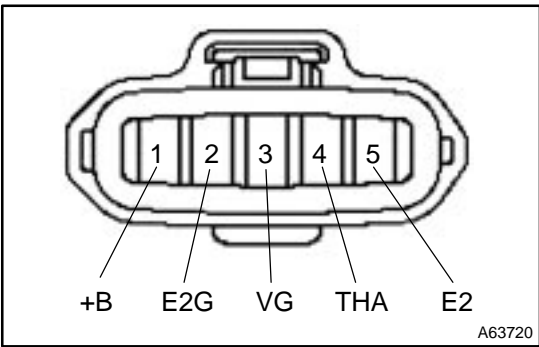

- (a) Disconnect the mass air flow meter connector.
- (b) Disconnect the ECM E4 connector.
- (c) Check continuity between the terminals VG of the mass air flow meter harness connector and VG of the ECM connector.

**Resistance: 1 Ω or less**

- (d) Check for open between the terminals E2G of the mass air flow meter connector and EVG of the ECM connector.

**Resistance: 1 Ω or less**

- (e) Check for short between the terminals VG and EVG of the ECM connector.

**Resistance: 1 MΩ or more**

- (f) Check for short between the terminals EVG and E2 of the ECM connector.

**Resistance: 1 MΩ or more**

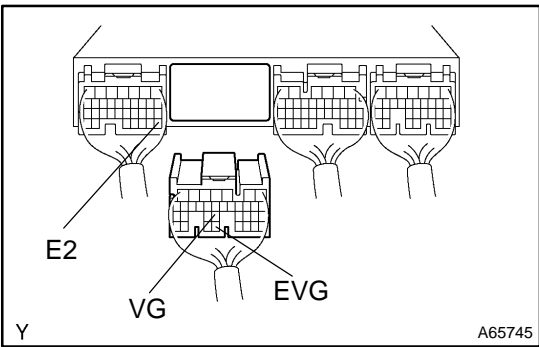

**NG** REPAIR OR REPLACE HARNESS AND CONNECTOR

**OK**

**REPLACE INTAKE AIR FLOW METER SUB-ASSY**

## 5 CHECK HARNESS AND CONNECTOR(E.F.I. RELAY-MASS AIR FLOW METER)

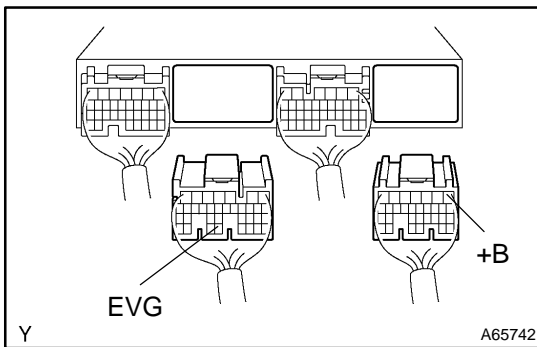

- (a) Disconnect the battery negative (-) terminal.
- (b) Disconnect the ECM E6 connector.
- (c) Check continuity between the terminals +B of the ECM connector and 3 of the E.F.I. relay installation relay block.  
**Resistance: 1  $\Omega$  or less**
- (d) Check continuity between the terminals E2G of the mass air flow meter connector and EVG of the ECM connector.  
**Resistance: 1  $\Omega$  or less**

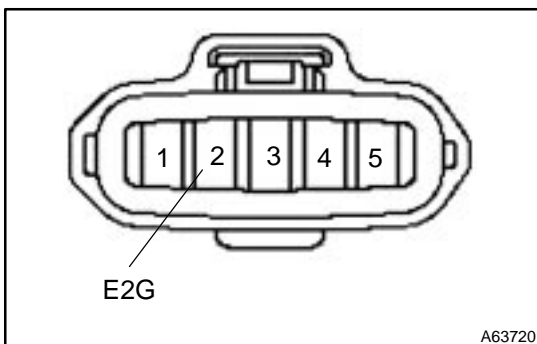
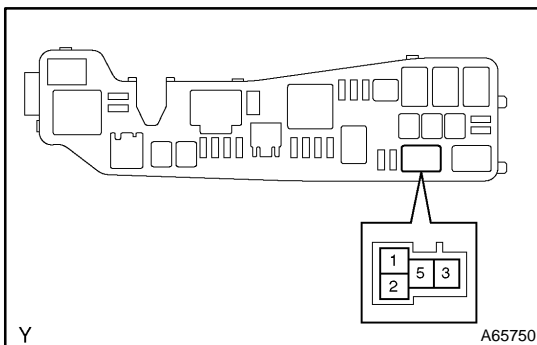

NG

**REPAIR OR REPLACE HARNESS AND CONNECTOR**

OK

**CHECK FOR ECM POWER SOURCE CIRCUIT**

**6 INSPECT ECM**

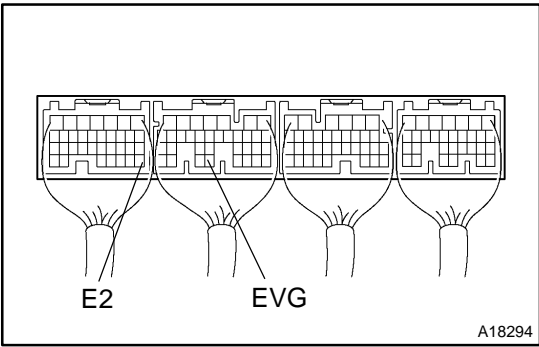

- (a) Check continuity between the terminals EVG and E2 of the ECM connector.  
**Resistance: 1 Ω or less**

**NG** CHECK AND REPLACE ECM

**OK**

**7 CHECK HARNESS AND CONNECTOR(ECM-MASS AIR FLOW METER)**

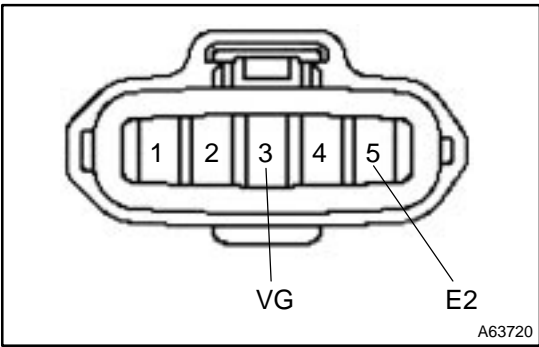

- (a) Disconnect the mass air flow meter connector.
- (b) Check for open between the terminals VG of the mass air flow meter connector and VG of the ECM connector.  
**Resistance: 1 Ω or less**

- (c) Check for open between the terminals E2 of the mass air flow meter harness connector and E2 of the ECM connector.  
**Resistance: 1 Ω or less**

- (d) Disconnect the ECM E3 and E4 connector.
- (e) Check for short between the terminals VG and E2 of the ECM connector.  
**Resistance: 1 MΩ or more**

- (f) Check for short between the terminals EVG and E2 of the ECM connector.  
**Resistance: 1 MΩ or more**

**NG** REPAIR OR REPLACE HARNESS AND CONNECTOR

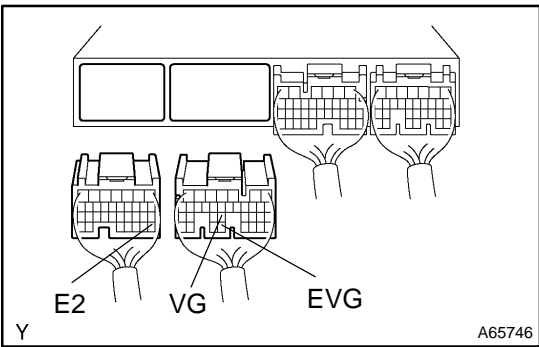

**OK**

**CHECK AND REPLACE ECM**