

DTC	P1656	OCV CIRCUIT MALFUNCTION (BANK 1)
------------	--------------	---

CIRCUIT DESCRIPTION

Refer to DTC P1349 on page [05-123](#).

DTC No.	DTC Detecting Condition	Trouble Area
P1656	Open or short in oil control valve circuit	<ul style="list-style-type: none"> • Open or short in oil control valve circuit • Oil control valve • ECM

WIRING DIAGRAM

Refer to DTC P1349 on page [05-123](#).

INSPECTION PROCEDURE

HINT:

Read freeze frame data using hand-held tester or OBD II scan tool. Because freeze frame records the engine conditions when the malfunction is detected, when troubleshooting it is useful for determining whether the vehicle was running or stopped, the engine warmed up or not, the air-fuel ratio lean or rich, etc. at the time of the malfunction

Hand-held tester:

1 | PERFORM ACTIVE TEST BY HAND-HELD TESTER(OCV OPERATION)

- (a) Start the engine and warm it up.
- (b) Connect the hand-held tester and select the VVT on the ACTIVE TEST menu.
- (c) Check the engine speed when operating the OCV by using the hand-held tester.

Result:

VVT system is OFF (OCV is OFF): Normal engine speed

VVT system is ON (OCV is ON): Rough idle or engine stalled

OK

CHECK FOR INTERMITTENT PROBLEMS

NG

2 | INSPECT CAMSHAFT TIMING OIL CONTROL VALVE ASSY (See page [10-2](#))

NG

REPLACE CAMSHAFT TIMING OIL CONTROL VALVE ASSY

OK

3 | INSPECT ECM(CHECK VOLTAGE) (See page [05-123](#))

NG

CHECK AND REPLACE ECM

OK

4 CHECK WIRE HARNESS OR CONNECTOR(ECM-OCV)

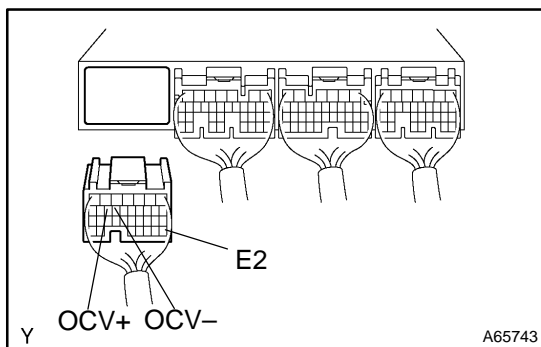

- Disconnect the ECM E3 connector.
- Disconnect the camshaft timing control valve connector.
- Check continuity between the terminals OCV+ of the ECM connector and 1 of the camshaft timing control valve connector.

Resistance: 1 Ω or less

- Check for short between the terminals OCV+ of the ECM connector and E2 of the ECM connector.

Resistance: 1 MΩ or more

- Check continuity between the terminals OCV- of the ECM connector and 2 of the camshaft timing control valve connector.

Resistance: 1 Ω or less

- Check for short between the terminals OCV- of the ECM connector and E2 of the ECM connector.

Resistance: 1 MΩ or more

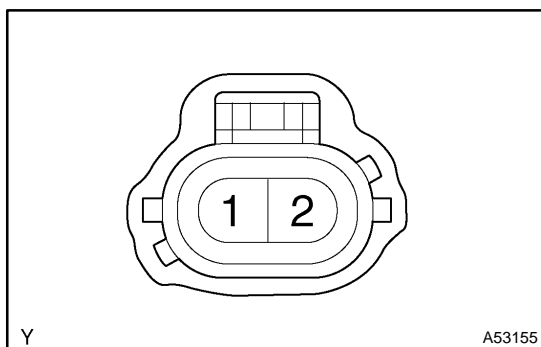

NG

REPAIR OR REPLACE WIRE HARNESS OR CONNECTOR

OK

CHECK FOR INTERMITTENT PROBLEMS

OBD II scan tool (excluding hand-held tester):

1 CHECK OPERATION OF OCV

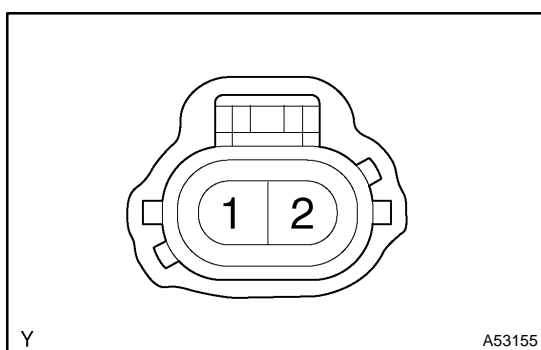

- Start the engine and warm it up.
- Disconnect the OCV connector.
- Apply battery positive voltage to the terminals of the OCV.
- Check the engine speed.

Result: Rough idle or engine stalled

NG

REPLACE CAMSHAFT TIMING OIL CONTROL VALVE ASSY

OK

2 INSPECT ECM(CHECK VOLTAGE)

NG

CHECK AND REPLACE ECM

OK

3 CHECK HARNESS AND CONNECTOR(ECM-OCV)

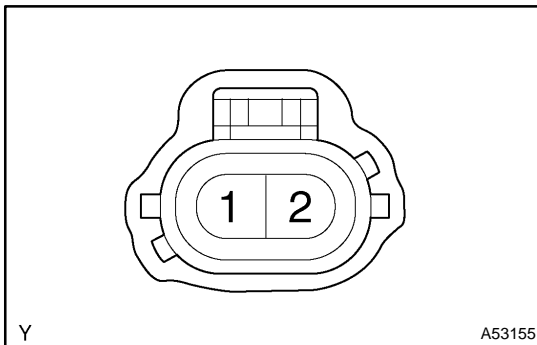
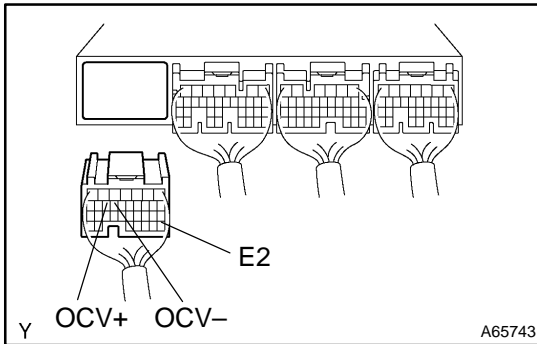

- (a) Disconnect the ECM E3 connector.
- (b) Disconnect the camshaft timing control valve connector.
- (c) Check continuity between the terminals OCV+ of the ECM connector and 1 of the camshaft timing control valve connector.
Resistance: 1 Ω or less
- (d) Check for short between the terminals OCV+ of the ECM connector and E2 of the ECM connector.
Resistance: 1 M Ω or more
- (e) Check continuity between the terminals OCV- of the ECM connector and 2 of the camshaft timing control valve connector.
Resistance: 1 Ω or less
- (f) Check for short between the terminals OCV- of the ECM connector and E2 of the ECM connector.
Resistance: 1 M Ω or more

NG

REPAIR OR REPLACE HARNESS AND CONNECTOR

OK

CHECK FOR INTERMITTENT PROBLEMS