

<b>DTC</b>	<b>P1520</b>	<b>STOP LIGHT SWITCH CIRCUIT MALFUNCTION</b>
------------	--------------	--

This signal is used to detect that the brakes have been applied. The STP signal voltage is the same as the one supplied to the stop lights. The STP signal is used mainly to control the fuel cut-off engine speed (The fuel cut-off engine speed is reduced slightly when the vehicle is braking.)

DTC No.	DTC Detecting Condition	Trouble Area
P1520	Stop light switch does not turn off when repeating driving at 30 km or more and 10 time or more after depressing brake (2 trip detection logic)	<ul style="list-style-type: none"> <li>• Short in stop light switch signal circuit</li> <li>• Stop light switch</li> <li>• ECM</li> </ul>

**WIRING DIAGRAM**

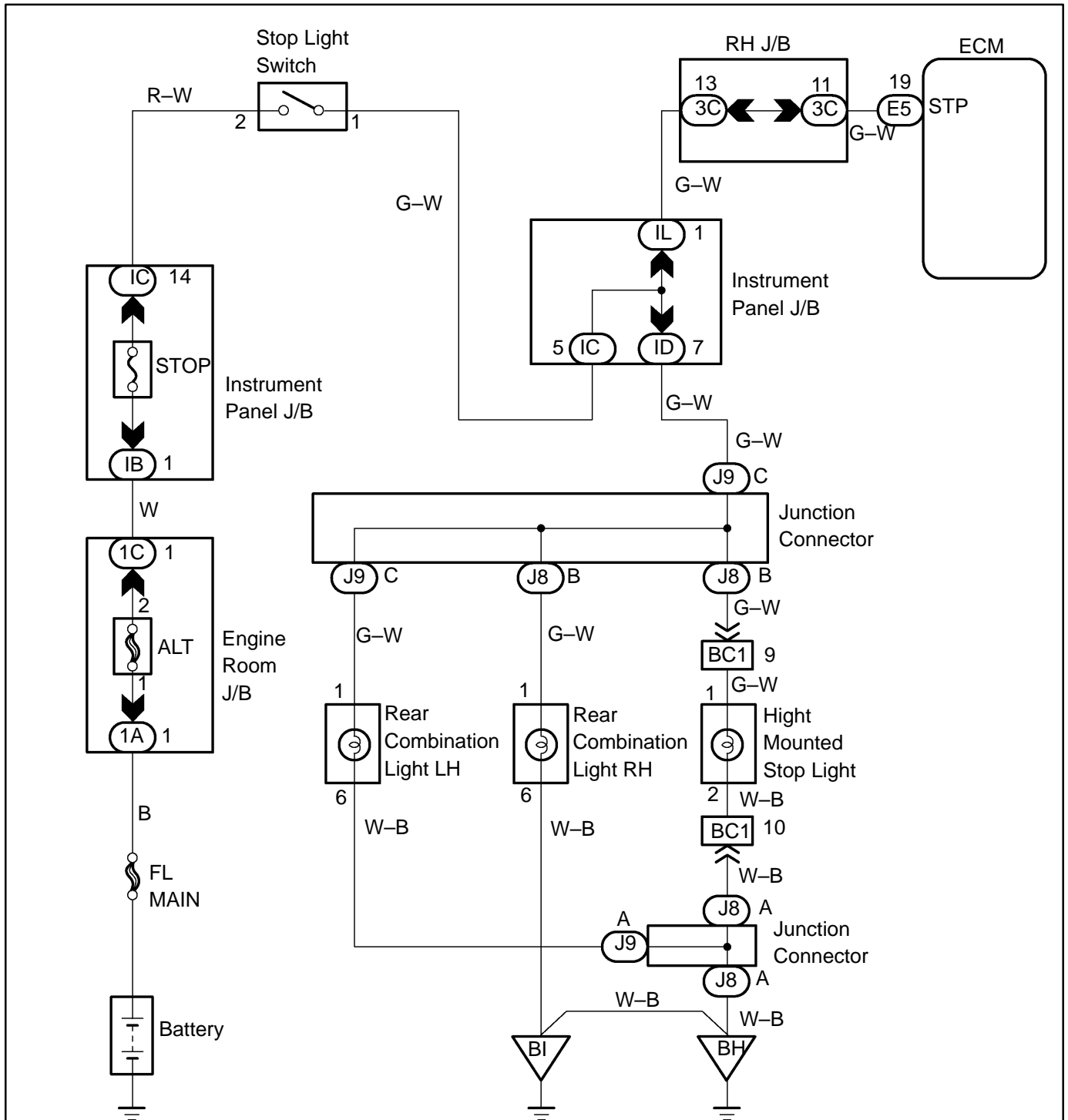

## INSPECTION PROCEDURE

### HINT:

Read freeze frame data using the hand-held tester or OBD II scan tool, as freeze frame data records the engine conditions when the malfunction is detected. When troubleshooting, it is useful for determining whether the vehicle was running or stopped, the engine was warmed up or not, the air-fuel ratio was lean or rich, etc. at the time of the malfunction.

### Hand-held tester:

#### 1 CHECK OPERATION OF STOP LIGHT

- (a) Check if the stop lights go on and off normally when the brake pedal is operated and released.

NG

REPAIR OR REPLACE STOP LIGHT SWITCH CIRCUIT

OK

#### 2 READ VALUE OF HAND-HELD TESTER

- (a) Connect the hand-held tester to the DLC3.  
 (b) Turn the ignition switch ON and push the hand-held tester main switch ON.  
 (c) Read the STP signal on the hand-held tester.

#### Result:

Brake Pedal	STP Signal
Depressed	ON
Released	OFF

OK

CHECK FOR INTERMITTENT PROBLEMS

NG

**3 CHECK WIRE HARNESS OR CONNECTOR(ECM-STOP LIGHT SWITCH)**

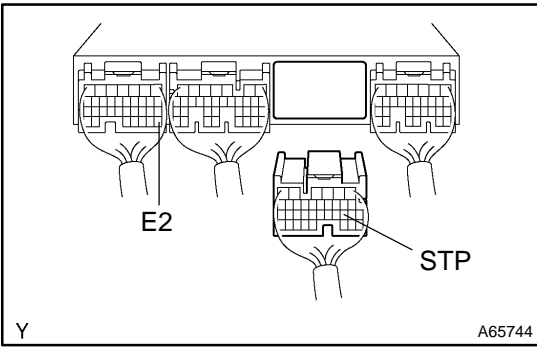

- (a) Disconnect the ECM E5 connector.
- (b) Disconnect the stop light connector.
- (c) Check for open between the terminals STP of the ECM connector and 1 of the stop light connector.  
**Resistance: 1 Ω or less**
- (d) Check for short between the terminals STP of the ECM connector and E2 of the ECM connector.  
**Resistance: 1 MΩ or more**

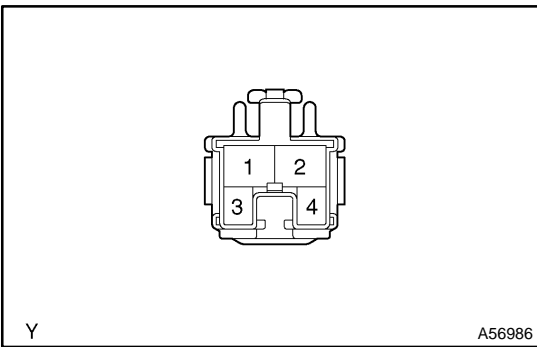

**NG** REPAIR OR REPLACE WIRE HARNESS OR CONNECTOR

**OK**

**CHECK AND REPLACE ECM**

**OBD II scan tool (excluding hand-held tester):**

**1 CHECK OPERATION OF STOP LIGHT**

- (a) Check if the stop lights go on and off normally when the brake pedal is operated and released.

**NG** REPAIR OR REPLACE STOP LIGHT SWITCH CIRCUIT

**OK**

**2 CHECK STP SIGNAL**

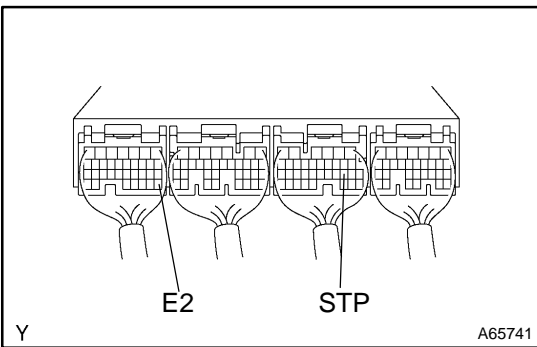

- (a) Turn the ignition switch ON.
- (b) Check the voltage between terminal STP and E2 of the ECM connector.

**Voltage:**

Brake Pedal	Voltage
Depressed	7.5 - 14 V
Released	Below 1.5 V

**OK** CHECK FOR INTERMITTENT PROBLEMS

**NG**

### 3 CHECK HARNESS AND CONNECTOR(ECM-STOP LIGHT SWITCH)

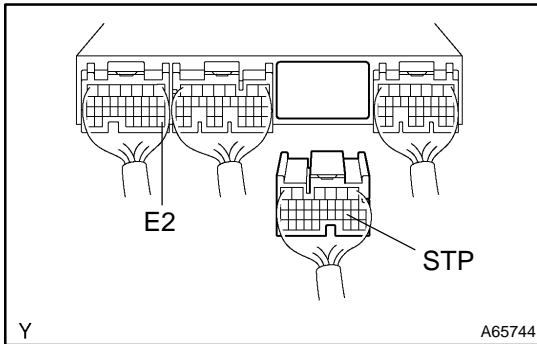

- (a) Disconnect the ECM E5 connector.
- (b) Disconnect the stop light connector.
- (c) Check for open between the terminals STP of the ECM connector and 1 of the stop light connector.  
**Resistance: 1  $\Omega$  or less**
- (d) Check for short between the terminals STP of the ECM E5 connector and E2 of the ECM E3 connector.  
**Resistance: 1 M $\Omega$  or more**

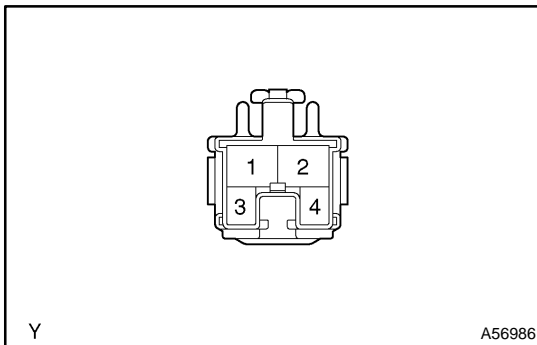

NG

**REPAIR OR REPLACE HARNESS AND CONNECTOR**

OK

**CHECK AND REPLACE ECM**