

DTC	P0441	EVAPORATIVE EMISSION CONTROL SYSTEM INCORRECT PURGE FLOW
------------	--------------	---

DTC	P0446	EVAPORATIVE EMISSION CONTROL SYSTEM MALFUNCTION
------------	--------------	--

CIRCUIT DESCRIPTION

The vapor pressure sensor, VSV for Canister Closed Valve (CCV), VSV for pressure switching valve are used to detect abnormalities in the evaporative emission control system.

The ECM decides whether or not there is an abnormality in the evaporative emission control system by the vapor pressure sensor signal.

DTCs P0441 and P0446 are recorded by the ECM when evaporative emissions leak from the components within the dotted line in Fig. 1 below, or when there is a malfunction in the VSV for EVAP, the VSV for pressure switching valve or in the vapor pressure sensor itself.

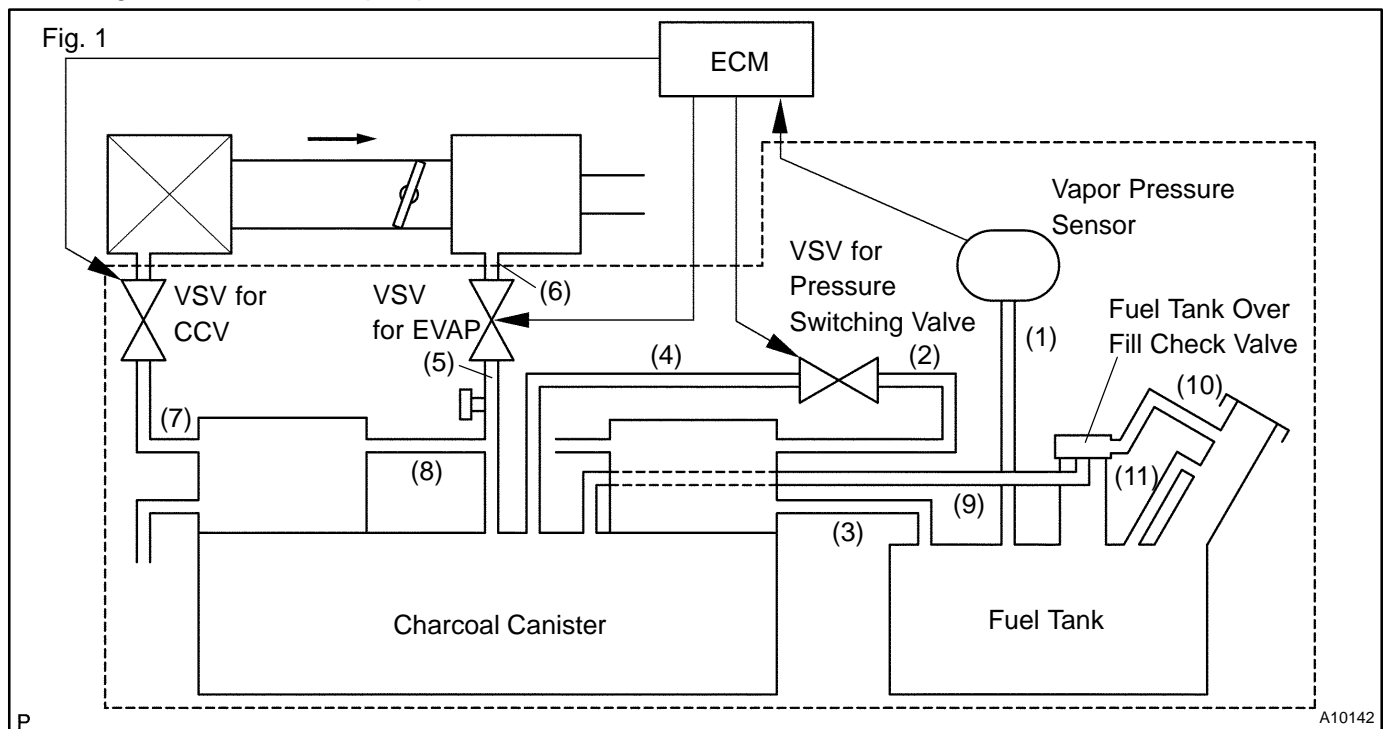

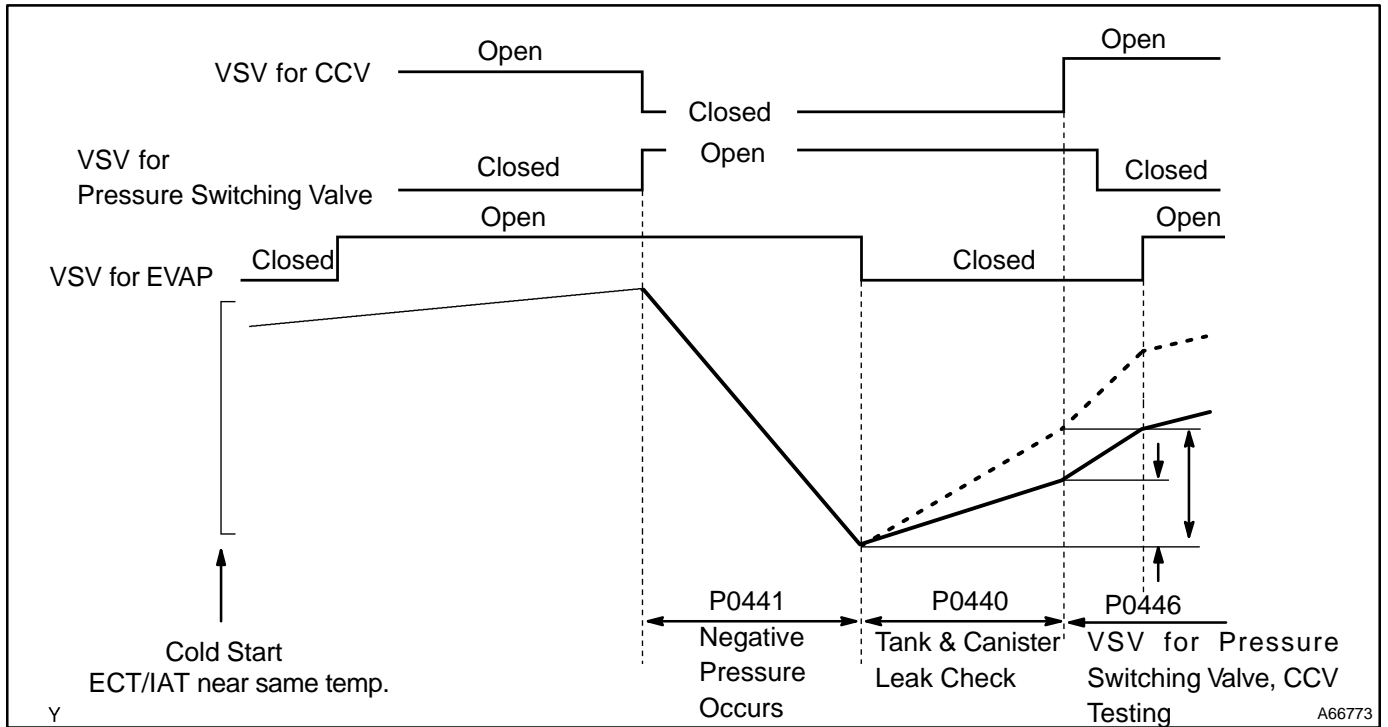

P0441:

The ECM closes the CCV and opens the VSV for pressure switching valve causing vacuum to increase in the entire EVAP system.

The ECM continues to operate the VSV for EVAP until the vacuum is increased to a specified point at which time the ECM closes the VSV for EVAP.

If the vacuum did not increase, or if the vacuum increased beyond the specified limit, the ECM judges the VSV for EVAP and related components to be faulty.

P0446:

When the vapor pressure rises to a specified point, the ECM opens the VSV for CCV. Pressure will increase rapidly because of the air allowed into the system. No increase or an increase below specified rate of pressure increase indicates a restriction on the air inlet side.

The ECM closes the VSV for pressure switching valve. This action blocks air entering the fuel tank side of system. The pressure rise on the fuel tank side is no longer as great.

If there was no change in pressure, the ECM will conclude the VSV for pressure switching valve did not close.

DTC No.	DTC Detecting Condition	Trouble Area
P0441	<ul style="list-style-type: none"> • Pressure in charcoal canister does not drop during purge control (2 trip detection logic) • During purge cut-off, pressure in charcoal canister is very low compared with atmospheric pressure (2 trip detection logic) 	<ul style="list-style-type: none"> • Vacuum hose cracks, holed, blocked, damaged or disconnected ((1), (2), (3), (4), (5), (7), (8), (9), (10) and(11) in Fig. 1) • Fuel tank cap incorrectly installed • Open or short in vapor pressure sensor circuit • Vapor pressure sensor
P0446	<ul style="list-style-type: none"> • When the vapor pressure rises to a specified point, the ECM opens the VSV for CCV. Pressure will increase rapidly because of the air allowed into the system. No increase or an increase below specified rate of pressure increase indicates a restriction on the air inlet side. • The ECM closes the VSV for pressure switching valve. The pressure rise is no longer as great. If there was no change in pressure, the ECM will conclude the VSV for pressure switching valve did not close. 	<ul style="list-style-type: none"> • Open or short in VSV circuit for EVAP • VSV for EVAP • Open or short in VSV circuit for CCV • VSV for CCV • Open or short in VSV circuit for pressure switching valve • VSV for pressure switching valve • Fuel tank cracked, holed or damaged • Charcoal canister cracked, holed or damaged • Fuel tank over fill check valve cracked or damaged • ECM

WIRING DIAGRAM

Refer to DTC P0440 on page 05-84.

INSPECTION PROCEDURE

HINT:

- If DTC P0441, P0446, P0450 or P0451 is output after DTC P0440, first troubleshoot DTC P0441, P0446, P0450 or P0451. If no other malfunctions than them are detected, troubleshoot DTC P0440 next.
- Read freeze frame data using the hand-held tester or OBD II scan tool, as freeze frame data records the engine conditions when the malfunction is detected. When troubleshooting, it is useful for determining whether the vehicle was running or stopped, the engine was warmed up or not, the air-fuel ratio was lean or rich, etc. at the time of the malfunction.

Hand-held tester:

1 PERFORM ACTIVE TEST BY HAND-HELD TESTER

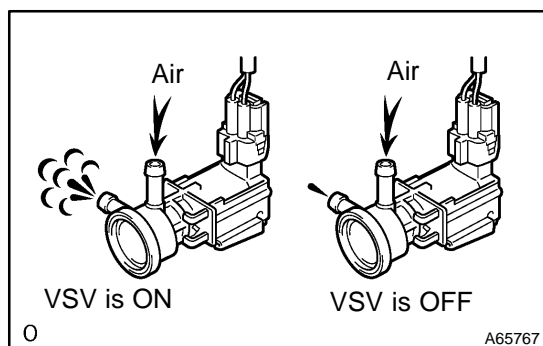

- Select the ACTIVE TEST mode on the hand-held tester.
- Disconnect the vacuum hose from the VSV for the EVAP.
- Start the engine.
- Select the item "EVAP VSV(ALONE)" in the ACTIVE TEST and operate the shift solenoid valves.
- When the VSV for the EVAP is operated by the hand-held tester, apply the disconnected hose to your finger to check the suction.

Result:

VSV is ON: Disconnected hose sucks.

VSV is OFF: Disconnected hose does not suck.

- Select the item "INTAKE CTL VSV1" in the ACTIVE TEST and operate the shift solenoid valves.

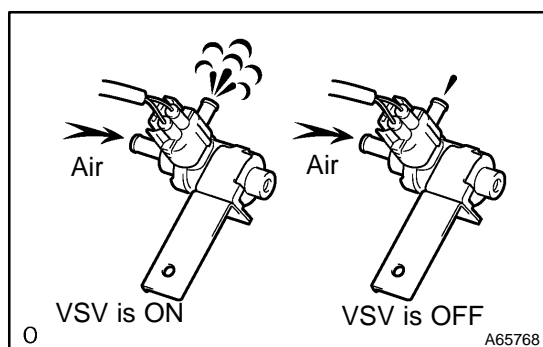

- Check the VSV for CCV operation when it is operated by the hand-held tester.

Result:

VSV is ON: Disconnected hose sucks.

VSV is OFF: Disconnected hose does not suck.

- Select the item "TANK BYPASS VSV" in the ACTIVE TEST and operate the shift solenoid valves.

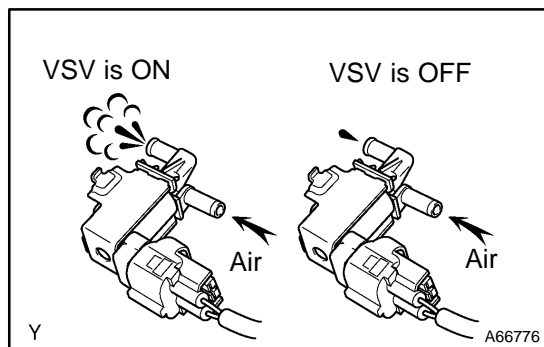

- (i) Check the VSV for pressure switching valve operation when it is operated by the hand-held tester.
Result:
VSV is ON: Disconnected hose sucks.
VSV is OFF: Disconnected hose does not suck.

NG → REPAIR OR REPLACE

OK

2 | PERFORM ACTIVE TEST BY EVAPORATIVE EMISSIONS LEAK

- (a) Connect the hand-held tester to the DLC3.
- (b) Select the "EVAP SYS CHECK" mode on the hand-held tester.
- (c) Perform "EVAP SYS CHECK".

DISPLAY:

A	B	C
Scan tool detects a leak on the fuel tank side.	Scan tool detects a leak on the canister side.	Scan tool does not detect a leak in the EVAP system.

B → Go to step NO TAG

C → CHECK VACUUM HOSE

A

3 | CHECK FUEL TANK CAP ASSY(TOYOTA GENUINE PARTS)

- (a) Replace to toyota genuine parts.
- (b) After replace, perform "EVAP SYS CHECK" by hand-held tester. (Go to step 2)

OK → Go to step NO TAG

NG

REPLACE TO TOYOTA GENUINE PARTS

4 CHECK FUEL TANK CAP FOR CORRECTLY INSTALLED

- (a) Correctly install fuel tank cap.
 (b) After install, perform "EVAP SYS CHECK" by hand-held tester. (Go to step 2)

OK Go to step NO TAG

NG

CORRECTLY INSTALL FUEL TANK CAP**5 INSPECT FUEL TANK CAP ASSY (See page 12-7)**

- (a) Replace to fuel tank cap assy.
 (b) After replace, perform "EVAP SYS CHECK" by hand-held tester. (Go to step 2)

OK Go to step NO TAG

NG

REPLACE FUEL TANK CAP ASSY**6 CHECK FUEL TANK INLET PIPE SUB-ASSY(FOR DAMAGE)**

- (a) Remove the fuel tank cap.
 (b) Visually inspect the fuel inlet pipe for damage.
 (c) After repair or replace, perform "EVAP SYS CHECK" by hand-held tester. (Go to step 2)

NG REPLACE FUEL TANK INLET PIPE SUB-ASSY

OK

REPAIR OR REPLACE VACUUM HOSE**7 CHECK FUEL HOSE(VSV FOR PRESSURE SWITCHING VALVE-CHARCOAL CANISTER)**

NG REPAIR OR REPLACE

OK

8 CHECK EACH VSV CONNECTOR FOR LOOSENESS AND DISCONNECTION

NG REPAIR OR CONNECT VSV OR SENSOR CONNECTOR

OK

9 CHECK VACUUM HOSE(8, 9, 10 AND 11 IN FIG.1 IN CIRCUIT DESCRIPTION)

- (a) Check that the vacuum hose is connected correctly.
- (b) Check the vacuum hose for looseness and disconnection.
- (c) Check the vacuum hose for cracks, hole, damage and blockage.

NG REPAIR OR REPLACE

OK

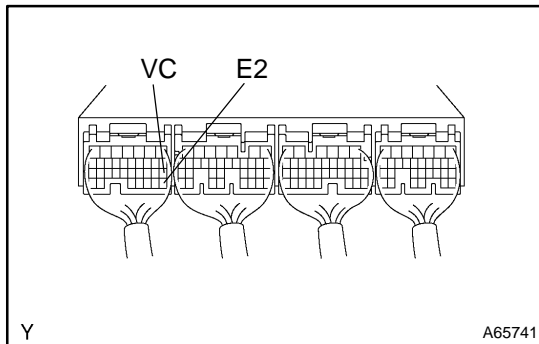
10 INSPECT ECM(CHECK VOLTAGE)

- (a) Turn the ignition switch ON.
- (b) Measure voltage between terminals VC and E2 of ECM E3 connector.
Voltage: 4.5 – 5.5 V

NG CHECK AND REPLACE ECM

OK

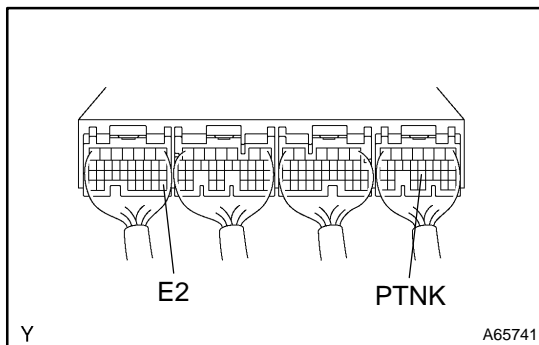
11 INSPECT ECM(CHECK VOLTAGE)

- (a) Remove the fuel tank cap.
- (b) Turn the ignition switch ON.
- (c) Measure the voltage between terminals PTNK of the ECM E6 connector and E2 of the ECM E3 connector.
Voltage: 3.0 – 3.6 V

OK Go to step NO TAG

NG

12 CHECK HARNESS AND CONNECTOR(VAPOR PRESSURE SENSOR-ECM)

NG REPAIR OR REPLACE HARNESS AND CONNECTOR

OK

REPLACE VAPOR PRESSURE SENSOR ASSY

13	CHECK VACUUM HOSE(INTAKE MANIFOLD-VSV FOR EVAP, VSV FOR EVAP-CHARCOAL CANISTER)
-----------	--

- (a) Check that the vacuum hose is connected correctly.
- (b) Check the vacuum hose for looseness and disconnection.
- (c) Check the vacuum hose for cracks, hole, damage and blockage.

NG	REPAIR OR REPLACE
-----------	--------------------------

OK

14	CHECK OPERATION OF VSV(FOR EVAP) (See page 12-1)
-----------	---

OK	Go to step NO TAG
-----------	--------------------------

NG

CHECK VACUUM HOSE

15	CHECK HARNESS AND CONNECTOR(E.F.I. RELAY-VSV FOR EVAP, VSV FOR EVAP-ECM)
-----------	---

NG	REPAIR OR REPLACE HARNESS AND CONNECTOR
-----------	--

OK

16	CHECK VACUUM HOSE(VSV FOR CCV-CHARCOAL CANISTER)
-----------	---

- (a) Check that the vacuum hose is connected correctly.
- (b) Check the vacuum hose for looseness and disconnection.
- (c) Check the vacuum hose for cracks, hole damage and blockage.

NG	CORRECTLY INSTALL FUEL TANK CAP
-----------	--

OK

17	CHECK OPERATION OF VSV(FOR CCV) (See page 12-1)
-----------	--

OK	Go to step NO TAG
-----------	--------------------------

NG

REPLACE VSV AND CHARCOAL CANISTER, AND THEN CLEAN VACUUM HOSE
--

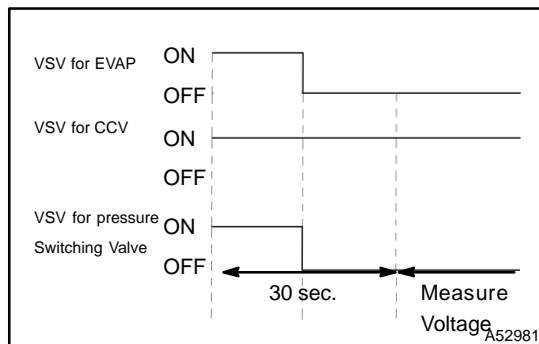
18 CHECK HARNESS AND CONNECTOR(E.F.I. RELAY-VSV FOR CCV, VSV FOR CCV-ECM)
NG
REPAIR OR REPLACE HARNESS AND CONNECTOR
OK
**19 CHECK OPERATION OF VSV(FOR PRESSURE SWITCHING VALVE)
(See page 12-1)**
OK
Go to step NO TAG
NG
REPLACE VSV AND CHARCOAL CANISTER, AND THEN CLEAN VACUUM HOSE
20 CHECK HARNESS AND CONNECTOR(E.F.I. RELAY-VSV FOR PRESSURE SWITCHING VALVE, VSV FOR PRESS)
NG
REPAIR OR REPLACE HARNESS AND CONNECTOR
OK
21 PERFORM ACTIVE TEST BY HAND-HELD TESTER(FUEL TANK ASSY)

- Connect the hand-held tester to the DLC3.
- Select the ACTIVE TEST mode on the hand-held tester.
- Start the engine.
- Switch the VSV for the CCV ON by the hand-held tester.
- Switch the VSV for the EVAP OFF and the VSV for the pressure switching valve ON by the hand-held tester and it remains on for 30 sec.
- Measure the voltage between terminals PTNK and E2 of the ECM connectors after switching the VSV for the EVAP from OFF to ON, and the VSV for the pressure switching valve from ON to OFF.

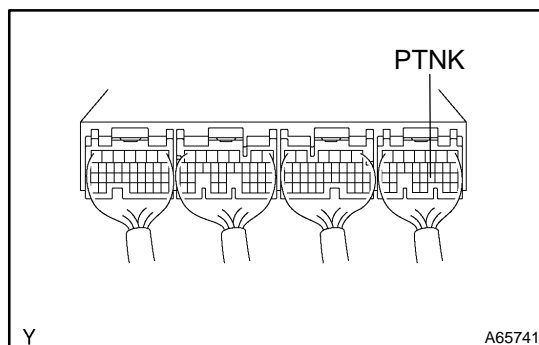
Voltage: 2.5 V or less

NG
REPLACE FUEL TANK ASSY
OK

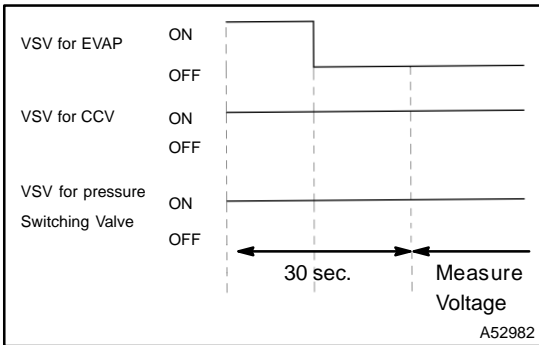
22 PERFORM ACTIVE TEST BY HAND-HELD TESTER(CHARCOAL CANISTER ASSY)

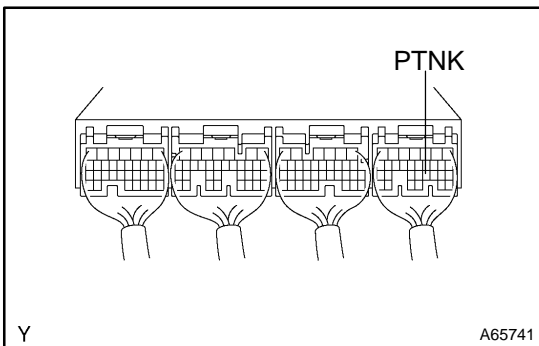

- (a) Connect the hand-held tester to the DLC3.
- (b) Select the ACTIVE TEST mode on the hand-held tester.
- (c) Start the engine.
- (d) Switch the VSV for the CCV ON by the hand-held tester.
- (e) Switch the VSV for the EVAP OFF and the VSV for the pressure switching valve ON by the hand-held tester and it remains on for 30 sec.
- (f) Measure the voltage between terminals PTNK and E2 of the ECM connectors after switching the VSV for the EVAP from OFF to ON.

Voltage: 2.5 V or less



NG → REPLACE CHARCOAL CANISTER ASSY

OK

23 CHECK CHARCOAL CANISTER ASSY (See page 12-7)

NG → REPLACE CHARCOAL CANISTER ASSY

OK

24 CHECK FUEL TANK OVER FILL CHECK VALVE (See page 11-7)

NG → REPLACE VSV AND CHARCOAL CANISTER, AND THEN CLEAN VACUUM HOSE

OK

REPLACE CHARCOAL CANISTER ASSY

OBD II scan tool (excluding hand-held tester):

1 CHECK EVAPORATIVE EMISSIONS LEAK

NG → REPAIR OR REPLACE

OK

2 CHECK FUEL TANK CAP ASSY(TOYOTA GENUINE PARTS)**NG** REPLACE TO TOYOTA GENUINE PARTS**OK****3 CHECK FUEL TANK CAP FOR CORRECTLY INSTALLED****NG** CORRECTLY INSTALL FUEL TANK CAP**OK****4 CHECK FUEL TANK CAP ASSY (See page 12-7)****NG** REPLACE FUEL TANK CAP ASSY**OK****5 CHECK FUEL TANK INLET PIPE SUB-ASSY(FOR DAMAGE)**

- (a) Remove the fuel tank cap.
(b) Visually inspect the fuel inlet pipe for damage.

NG REPLACE FUEL TANK INLET PIPE SUB-ASSY**OK****6 CHECK VACUUM HOSE(VAPOR PRESSURE SENSOR-FUEL TANK, CHARCOAL CANISTER-VSV FOR P)****NG** REPAIR OR CONNECT VSV OR SENSOR CONNECTOR**OK****7 CHECK FUEL HOSE(FUEL TANK-CHARCOAL CANISTER)****NG** REPAIR OR REPLACE**OK****8 CHECK EACH VSV CONNECTOR FOR LOOSENESS AND DISCONNECTION****NG** REPAIR OR CONNECT VSV OR SENSOR CONNECTOR**OK**

9 CHECK VACUUM HOSE

- Check that the vacuum hose is connected correctly.
- Check the vacuum hose for looseness and disconnection.
- Check the vacuum hose for cracks, hole damage and blockage.

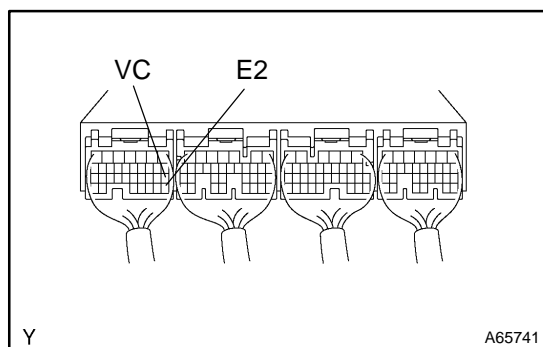
NG**CHECK FUEL TANK OVER FILL CHECK VALVE****OK****10 INSPECT ECM(VC-E2)**

- Turn the ignition switch ON.
- Measure voltage between terminals VC and E2 of ECM E3 connector.
Voltage: 4.5 – 5.5 V

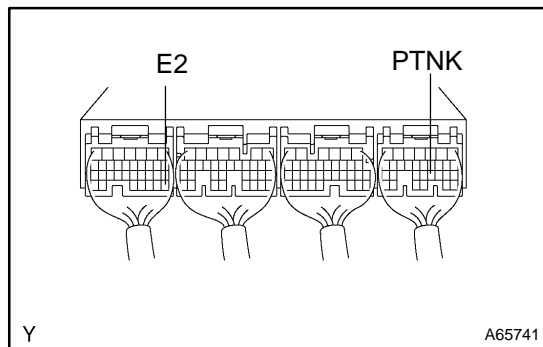
NG**CHECK AND REPLACE ECM****OK****11 INSPECT ECM(PTNK-E2)**

- Remove the fuel tank cap.
- Turn the ignition switch ON.
- Measure the voltage between terminals PTNK of the ECM E6 connector and E2 of the ECM E3 connector.
Voltage: 3.0 – 3.6 V

OK**Go to step NO TAG****NG****12 CHECK HARNESS AND CONNECTOR(VAPOR PRESSURE SENSOR-ECM)****NG****REPAIR OR REPLACE HARNESS AND CONNECTOR****OK****REPLACE VAPOR PRESSURE SENSOR ASSY**

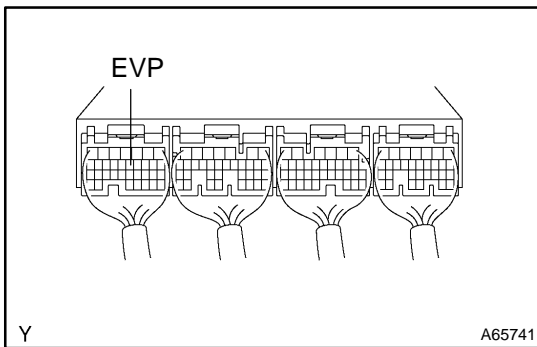
13 CHECK VSV(FOR EVAP)

- (a) Turn the ignition switch ON.
- (b) Check the VSV function.
 - (1) Connect the terminal EVP of the ECM E3 connector and the body ground (VSV ON).
 - (2) Disconnect the terminal EVP of the ECM E3 connector and body ground (VSV OFF).

(1) VSV is ON:

Air from port E flows out through port F.

(2) VSV is OFF:

Air from port E flows out through port F with a little difficulty.

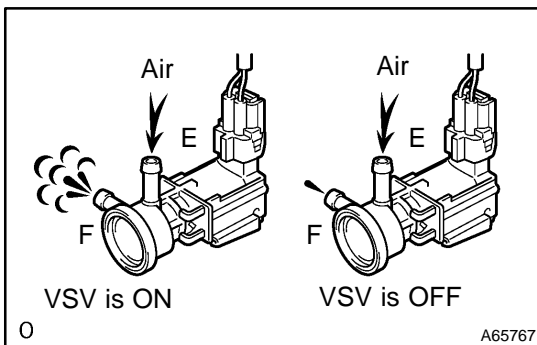

OK

Go to step NO TAG

NG

14 CHECK OPERATION OF VSV(FOR EVAP) (See page 12-1)

OK

Go to step NO TAG

NG

REPLACE VSV AND CHARCOAL CANISTER, AND THEN CLEAN VACUUM HOSE

15 CHECK HARNESS AND CONNECTOR(E.F.I. RELAY-VSV FOR EVAP, VSV FOR EVAP-ECM)

NG

REPAIR OR REPLACE HARNESS AND CONNECTOR

OK

CHECK AND REPLACE ECM

16 CHECK VSV(FOR CCV)

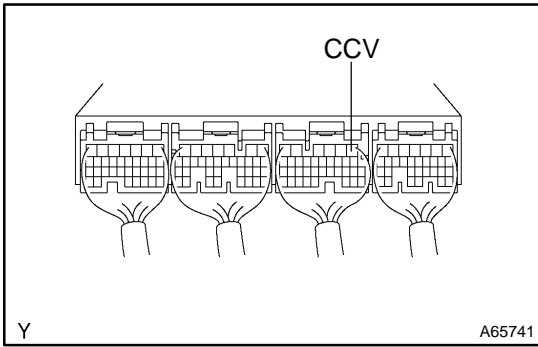

- (a) Turn the ignition switch ON.
 - (b) Check the VSV function.
 - (1) Connect the terminal CCV of the ECM E5 connector and the body ground (VSV ON).
 - (2) Disconnect the terminal CCV of the ECM E5 connector and the body ground (VSV OFF).
- VSV is ON: Air does not flow from port E to port F.**
VSV is OFF: Air from port E flows out through port F.

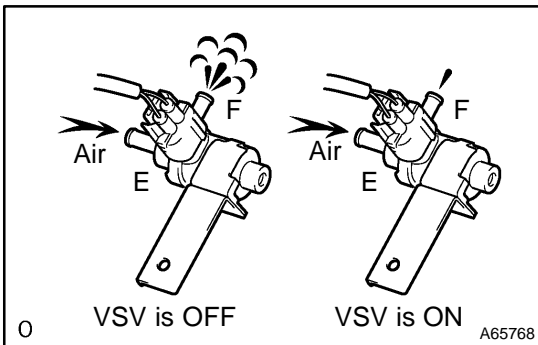

OK → Go to step NO TAG

NG

17 CHECK OPERATION OF VSV(FOR CCV) (See page 12-1)

OK → Go to step NO TAG

NG

REPLACE VSV AND CHARCOAL CANISTER, AND THEN CLEAN VACUUM HOSE

18 CHECK HARNESS AND CONNECTOR(E.F.I. RELAY-VSV FOR CCV, VSV FOR CCV-ECM)

NG → REPAIR OR REPLACE HARNESS AND CONNECTOR

OK

CHECK AND REPLACE ECM

19	CHECK VSV(FOR PRESSURE SWITCHING VALVE)
-----------	--

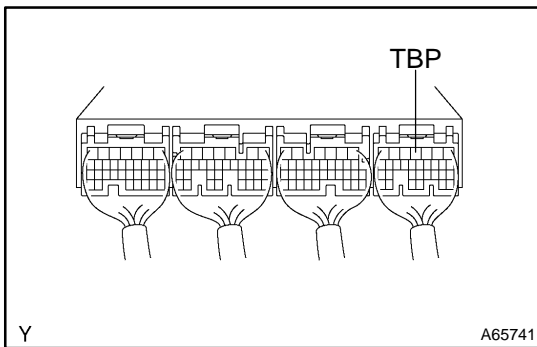

- (a) Turn the ignition switch ON.
 (b) Check the VSV function.
- (1) Connect the terminal TBP of the ECM E6 connector and the body ground (VSV ON).
 - (2) Disconnect the terminal TBP of the ECM E6 connector and the body ground (VSV OFF).
- (1) VSV is ON:**
 Air from port E flows out through port F.
- (2) VSV is OFF:**
 Air does not flow from port E to port F.

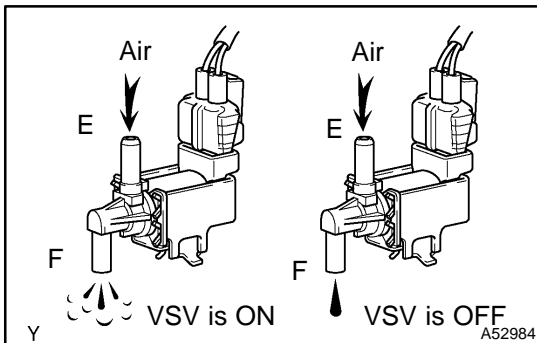

OK	Go to step NO TAG
----	-------------------

NG

20	CHECK OPERATION OF VSV(FOR PRESSURE SWITCHING VALVE) (See page 12-7)
-----------	--

OK	Go to step NO TAG
----	-------------------

NG

REPLACE VSV AND CHARCOAL CANISTER, AND THEN CLEAN VACUUM HOSE
--

21	CHECK HARNESS AND CONNECTOR(E.F.I. RELAY-VSV FOR PRESSURE SWITCHING VALVE, VSV FOR PRESS)
-----------	--

NG	REPAIR OR REPLACE HARNESS AND CONNECTOR
----	---

OK

CHECK AND REPLACE ECM

22	CHECK FUEL TANK OVER FILL CHECK VALVE
----	---------------------------------------

NG	REPLACE FUEL TANK OVER FILL CHECK VALVE OR FUEL TANK
----	--

OK

CHECK AND REPLACE ECM
