

<b>DTC</b>	<b>P0115</b>	<b>ENGINE COOLANT TEMP. CIRCUIT MALFUNCTION</b>
------------	--------------	---

**CIRCUIT DESCRIPTION**

A thermistor built into the engine coolant temp. sensor changes the resistance value according to the engine coolant temp.

The structure of the sensor and connection to the ECM is the same as in the intake air temp. circuit malfunction shown on page 05-31.

If the ECM detects the DTC P0115, it operates fail safe function in which the engine coolant temperature is assumed to be 80°C (176°F).

DTC No.	Detection Item	Trouble Area
P0115	Open or short in engine coolant temp. sensor circuit	<ul style="list-style-type: none"> <li>• Open or short in engine coolant temp. sensor circuit</li> <li>• Engine coolant temp. sensor</li> <li>• ECM</li> </ul>

**HINT:**

After confirming DTC P0115, use the hand-held tester or OBD II scan tool to confirm the engine coolant temp. from "CURRENT DATA".

Temp. Displayed	Malfunction
-40°C (-40°F)	Open circuit
140°C (284°F) or more	Short circuit

**WIRING DIAGRAM**

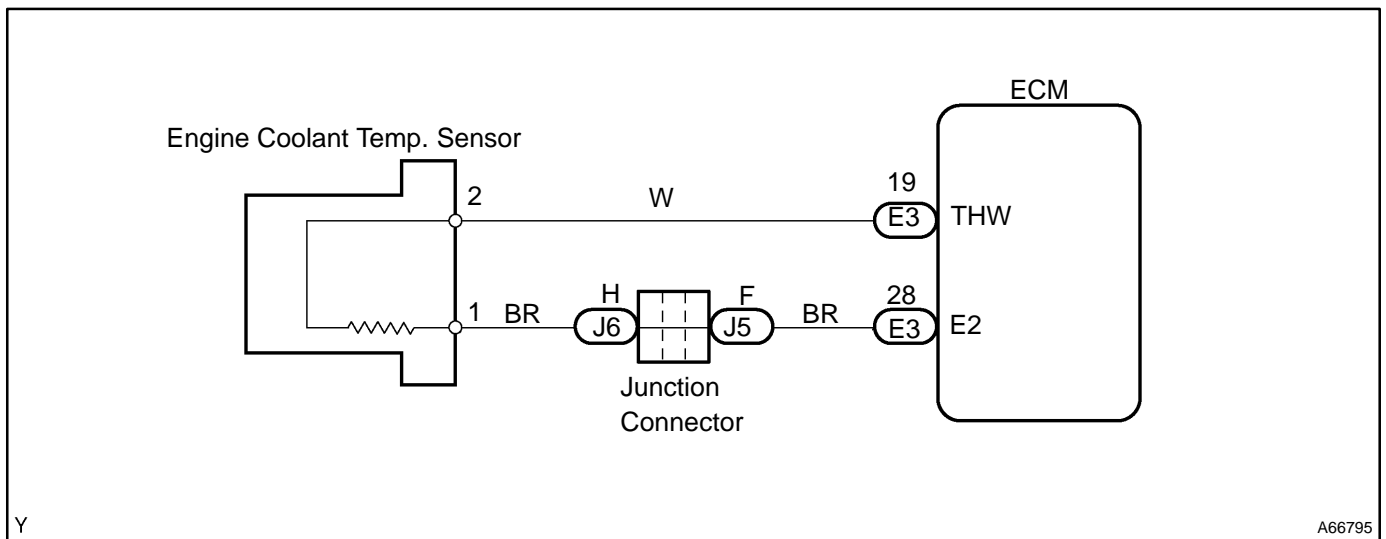

**INSPECTION PROCEDURE**

**HINT:**

- If DTC P0100 (Mass Air Flow Meter Circuit Malfunction), P0101 (Mass Air Flow Meter Circuit Range/Performance Problem), P0110 (Intake Air Temp. Circuit Malfunction), P0115 (Engine coolant Temp. Circuit Malfunction), P0120 (Throttle/Pedal Position Sensor/Switch "A" Malfunction) are output simultaneously, E1, E2 etc. (Sensor Ground system) may be open.
- Read freeze frame data using hand-held tester or OBD II scan tool. Because freeze frame records the engine conditions when the malfunction is detected, when troubleshooting it is useful for determining whether the vehicle was running or stopped, the engine warmed up or not, the air-fuel ratio lean or rich, etc. at the time of the malfunction.

<b>1</b>	<b>READ VALUE OF OBD II SCAN TOOL OR HAND-HELD TESTER(ENGINE COOLANT TEMPERATURE)</b>
----------	---

- (a) Read temperature value on the hand-held tester or OBD II scan tool.

**Temperature: Same as actual water temperature**

**Result:**

A	B	C
-40°C (-40°F)	140°C (284°F)	OK

**B** → **Go to step 4**

**C** → **CHECK FOR INTERMITTENT PROBLEMS**

**A**

<b>2</b>	<b>READ VALUE OF OBD II SCAN TOOL OR HAND-HELD TESTER(CHECK FOR OPEN IN HARNESS)</b>
----------	--



- (a) Disconnect the engine coolant temperature sensor connector.  
 (b) Connect the terminals 1 with 2 of the engine coolant temperature sensor connector.  
 (c) Turn the ignition switch ON.  
 (d) Read temperature value on the hand-held tester or OBD II scan tool.

**Temperature: 140°C (284°F) or more**

**OK** → **REPLACE E.F.I. ENGINE COOLANT TEMPERATURE SENSOR**

**NG**

<b>3</b>	<b>READ VALUE OF OBD II SCAN TOOL OR HAND-HELD TESTER(CHECK FOR OPEN IN ECM)</b>
----------	--

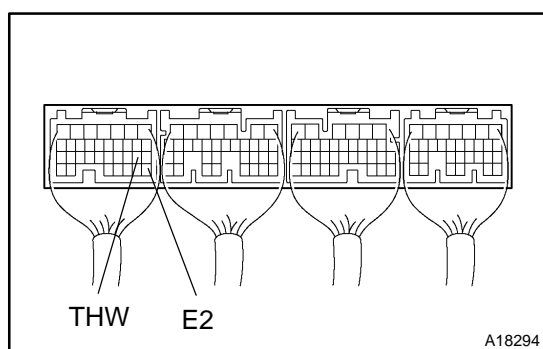

- (a) Connect the terminals THW with E2 of the ECM connector.  
 (b) Turn the ignition switch ON.  
 (c) Read temperature value on the hand-held tester or OBD II scan tool.

**Temperature: 140°C (284°F) or more**

**OK** → **REPAIR OR REPLACE HARNESS AND CONNECTOR**

**NG**

**CHECK AND REPLACE ECM**

<b>4</b>	<b>READ VALUE OF OBD II SCAN TOOL OR HAND-HELD TESTER(CHECK FOR SHORT IN HARNESS)</b>
----------	---

- (a) Disconnect the water temp. sensor connector.
- (b) Turn the ignition switch ON.
- (c) Read temperature value on the hand-held tester or OBD II scan tool.

**Temperature: -40°C (-40°F)**

**OK**

**REPLACE E.F.I. ENGINE COOLANT TEMPERATURE SENSOR**

**NG**

<b>5</b>	<b>READ VALUE OF OBD II SCAN TOOL OR HAND-HELD TESTER(CHECK FOR SHORT IN ECM)</b>
----------	---

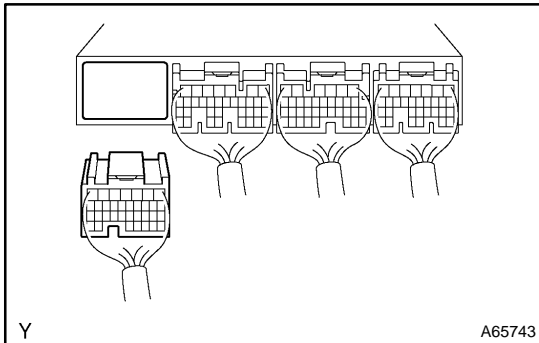

- (a) Disconnect the ECM E3 connector.
- (b) Turn the ignition switch ON.
- (c) Read temperature value on the hand-held tester or OBD II scan tool.

**Temperature: -40°C (-40°F)**

**OK**

**REPAIR OR REPLACE HARNESS AND CONNECTOR**

**NG**

**CHECK AND REPLACE ECM**