

FUEL PUMP CONTROL CIRCUIT

CIRCUIT DESCRIPTION

In the diagram below, when the engine is cranked, current flows from terminal ST of the ignition switch to the starter relay coil and also current flows to terminal STA of ECM (STA signal).

When the STA signal and NE signal are input to the ECM, Tr is turned ON, current flows to the coil of the circuit opening relay, the relay switches on, power is supplied to the fuel pump and the fuel pump operates. While the NE signal is generated (engine running), the ECM keeps Tr ON (circuit opening relay ON) and the fuel pump also keeps operating.

WIRING DIAGRAM

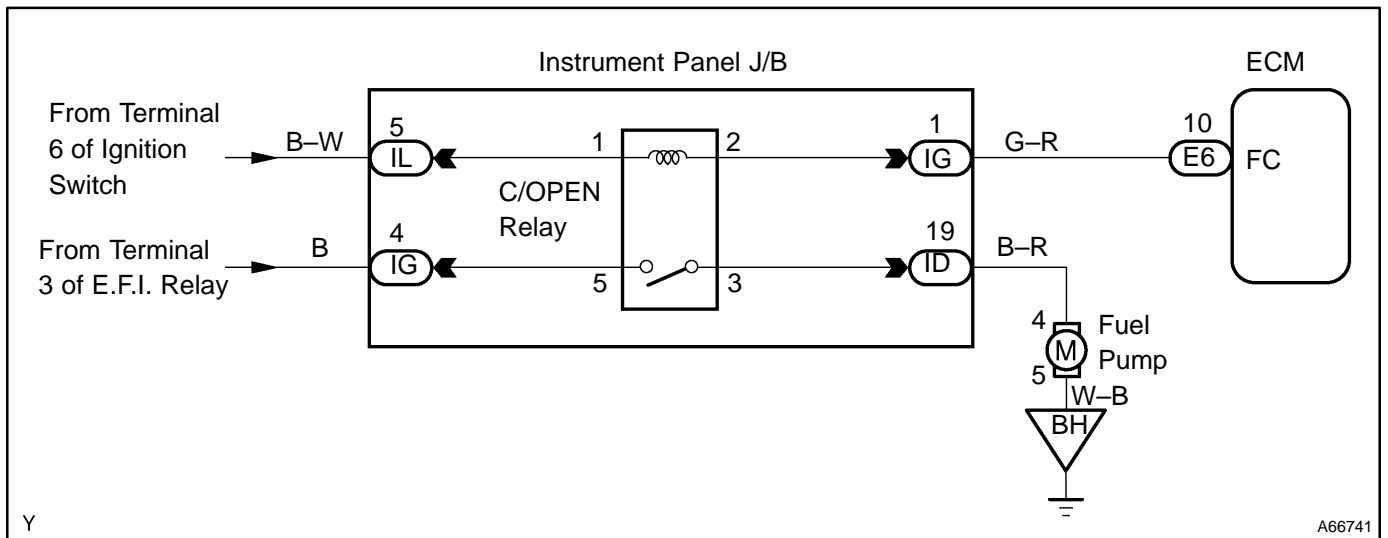

INSPECTION PROCEDURE

Hand-held tester:

1	PERFORM ACTIVE TEST BY HAND-HELD TESTER(OPERATION OF CIRCUIT OPENING RELAY)
---	--

- (a) Connect the hand-held tester to the DLC3.
- (b) Turn the ignition switch ON and push the hand-held tester main SW ON.
- (c) Select the item "FUEL PUMP / SPD" in the ACTIVE TEST.
- (d) Turn the ignition switch ON, and perform the active test at the engine stop.

Result: The circuit opening relay operates.

OK

PROCEED TO NEXT CIRCUIT INSPECTION SHOWN ON PROBLEM SYMPTOMS TABLE

NG

2 CHECK FOR ECM POWER SOURCE CIRCUIT (See page 05-148)

NG REPAIR OR REPLACE

OK

3 INSPECT E.F.I. CIRCUIT OPENING RELAY ASSY (See page 10-2)

NG REPLACE E.F.I. CIRCUIT OPENING RELAY ASSY

OK

4 INSPECT ECM(CHECK VOLTAGE)

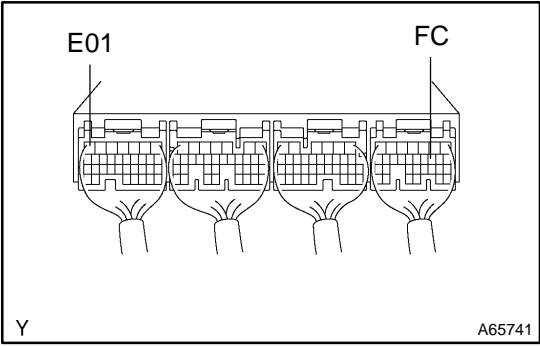

- (a) Turn the ignition switch ON.
 - (b) Measure the voltage between terminal FC and E01 of the ECM connector.
- Voltage: 9 - 14 V**

OK Go to step 6

NG

5 CHECK WIRE HARNESS OR CONNECTOR(E.F.I. RELAY-E.F.I. CIRCUIT OPENING RELAY, E.F.I. CIRCUIT OPNING RELAY) (See page 01-34)

NG REPAIR OR REPLACE WIRE HARNESS OR CONNECTOR

OK

CHECK AND REPLACE ECM

6 INSPECT FUEL PUMP (See page 11-7)

NG REPLACE FUEL PUMP

OK

7	CHECK WIRE HARNESS OR CONNECTOR(CHECK FOR OPEN)
----------	--

- (a) Check for open in harness and connector between E.F.I. circuit opening relay and fuel pump, and fuel pump and body ground.

Result: Continuity

NG

REPAIR OR REPLACE WIRE HARNESS OR CONNECTOR

OK

CHECK AND REPLACE ECM

OBD II scan tool (excluding hand-held tester):

1	CHECK OPERATION OF FUEL PUMP
----------	-------------------------------------

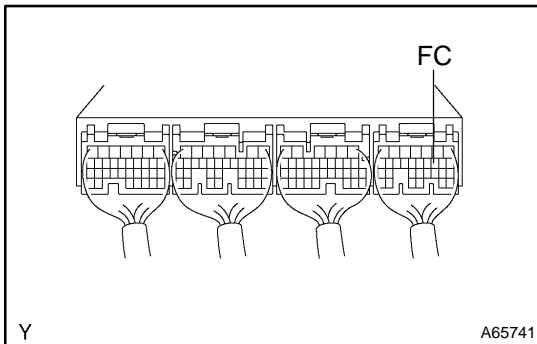

- (a) Turn the ignition switch ON.
 (b) Connect between terminal FC of the ECM E6 connector and the body ground.
 (c) Check for fuel pressure in the fuel inlet hose when it is pinched off.

Result: There is pressure in fuel inlet hose.

HINT:

At this time, you will hear the fuel return flowing noise.

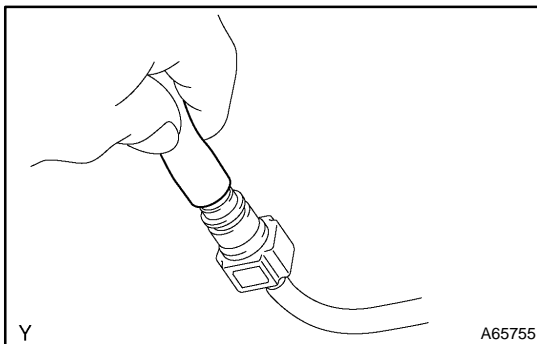

OK

PROCEED TO NEXT CIRCUIT INSPECTION SHOWN ON PROBLEM SYMPTOMS TABLE

NG

2	CHECK FOR ECM POWER SOURCE CIRCUIT (See page 05-148)
----------	---

NG

REPAIR OR REPLACE

OK

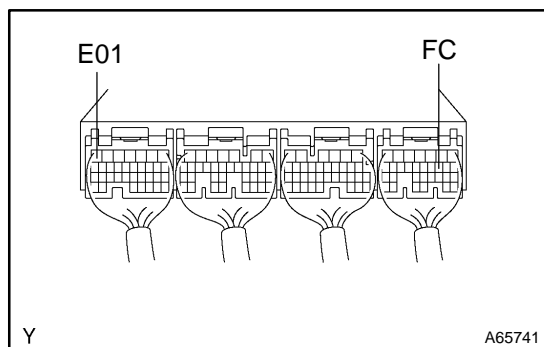
3 INSPECT E.F.I. CIRCUIT OPENING RELAY ASSY (See page 10-2)**NG****REPLACE E.F.I. CIRCUIT OPENING RELAY ASSY****OK****4 INSPECT ECM(CHECK VOLTAGE)**

- (a) Turn the ignition switch ON.
 (b) Measure the voltage between terminal FC of the ECM connector and E01 of the ECM connector.

Voltage: 9 - 14 V**OK****Go to step 6****NG****5 CHECK WIRE HARNESS OR CONNECTOR(E.F.I. RELAY-E.F.I. CIRCUIT OPENING RELAY, E.F.I. CIRCUIT OPENING RELAY)****OK****REPAIR OR REPLACE WIRE HARNESS OR CONNECTOR****NG****CHECK AND REPLACE ECM****6 INSPECT FUEL PUMP (See page 11-7)****NG****REPLACE FUEL PUMP****OK****7 CHECK WIRE HARNESS OR CONNECTOR(OPEN BETWEEN TERMINAL 3 OF E.F.I. CIRCUIT OPENING RELAY AND TERMINAL)****NG****REPAIR OR REPLACE WIRE HARNESS OR CONNECTOR****OK****CHECK AND REPLACE ECM**